

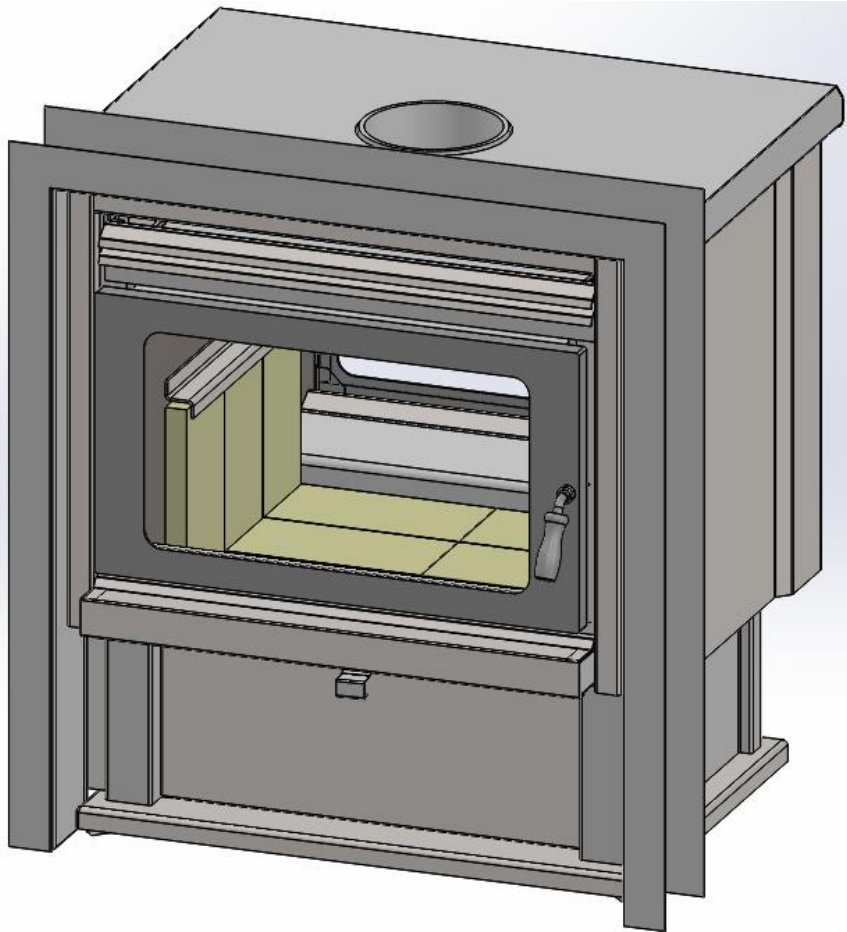

Specialists in fireplace design and manufacture

COUPE WALL PENETRATION
INSTALLATION & OPERATING INSTRUCTIONS



IMPORTANT:

INSTALLER, PLEASE LEAVE THESE INSTRUCTIONS WITH THE UNIT ON COMPLETION.

10 YEAR FIREBOX WARRANTY

The firebox is covered by a 10 year warranty.
Other parts are covered by a one year limited warranty.

Head Office – 13 French Avenue, Brendale, Queensland 4500
Telephone – PH: (07) 3490 5500
Facsimile – FAX: (07) 3490 5520
Website: - www.jetmaster.com.au
Business hours: - Monday to Thursday 7:30am-4:00pm. Friday 7:30am-2:00pm
Email: - sales@jetmaster.com.au

DIMENSIONS

TWO DOOR DOUBLE SIDED UNIT
CENTRE FLUE SUIT BUILDING INTO MASONRY

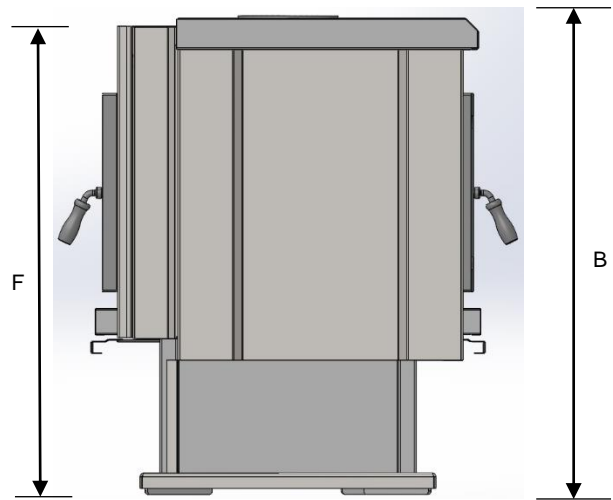
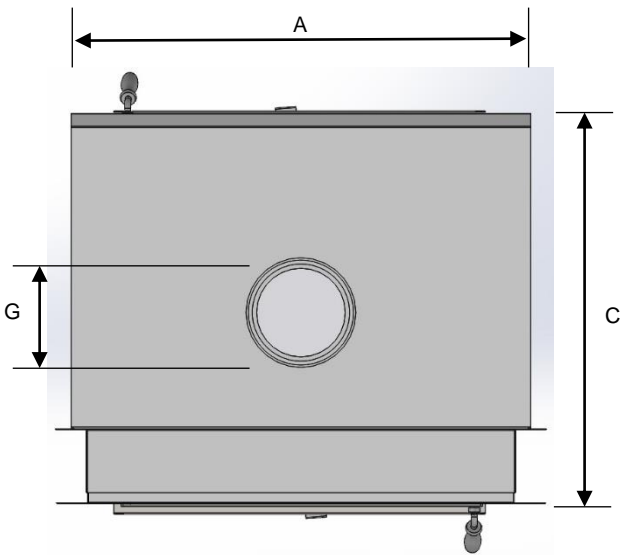
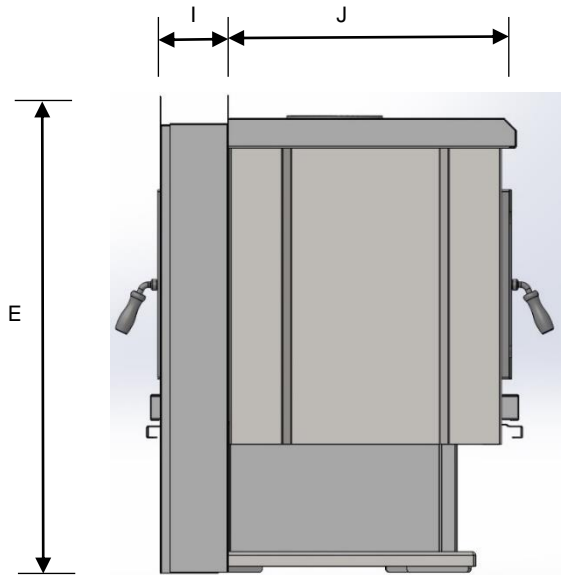
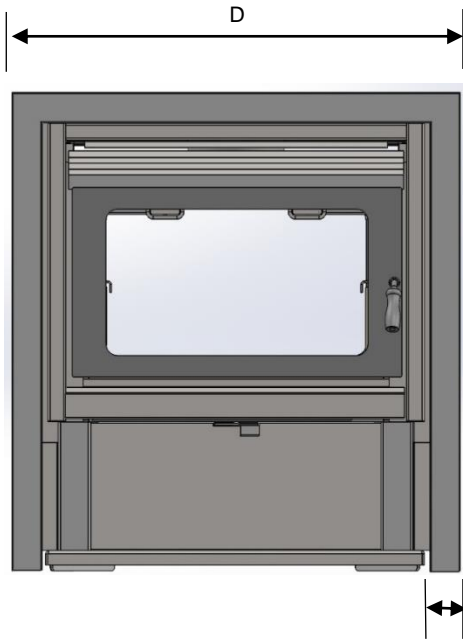

FASCIA NOT SHOWN

	A	B	C	D	E	F	G	I	J
MEASUREMENT	722	775	600	770	828	763	155	100	500

U SECTION / LINTEL TO BE SET INTO BRICK PANEL.
NOTE WELL : - SURROUND MUST SIT ON TOP OF FINAL HEIGHT OF HEARTH.
MAY BE INSTALLED THROUGH EXISTING WALL
TIMBER OR BRICK – AS PER MANUFACTURERS INSTRUCTIONS

INSTALLATION INSTRUCTION

COUPE (2 DOOR) WALL PENETRATION INSTALLATION

1. Locate desired position. Check that there are no trusses or beams in the ceiling to obstruct the flue on the free standing side of the wall
2. Cut hole in the wall minimum. 1300mm wide and 1500mm high. NOTE: if brickwork is taken to the ceiling a standard kit may be used. If any combustible wall is left above brickwork a treble kit must be used to prevent wall damage (figure 2).
3. If the floor is wooden secure a 1200mm x 1200mm piece of A C sheet to the floor as per figure 1. this should protrude 370mm from centre line of wall flush side and 830mm from centre line on free standing side.
4. Lay bricks on A C sheet as per figure 1. This will give correct size hearths on both sides of the wall. If floor is cement then tiles or slate may be used instead of bricks.
5. Position combination surround / lintel on TOP of hearth and in a central position. Check levels.
6. Lay masonry as per figure 2. with normal bricks there will be approx. 45mm gap between end of brick & inside vertical face of surround. This may be filled with mortar (figure 1). Adjust mortar so that 9th course finishes level with inside horizontal flat section of surround. Finish brick work in normal way using surround as lintel (figure 2).
7. After wall is completed slide fireplace into position. If you remove the doors during this operation it makes life easier. Ensure they are replaced on original sides.
8. Install flue kit as per figure 2.

NOTE: When the fireplace is installed in this way there will be a concealed 5mm gap all round between unit and surround to allow for expansion.

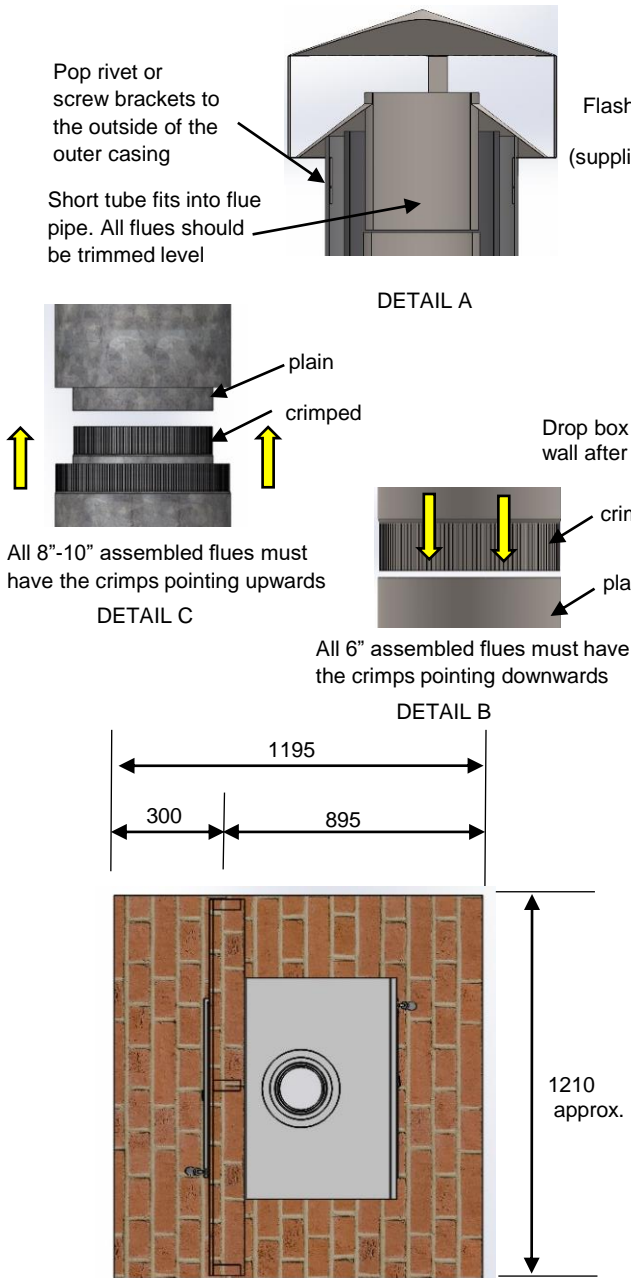

Fig. 1

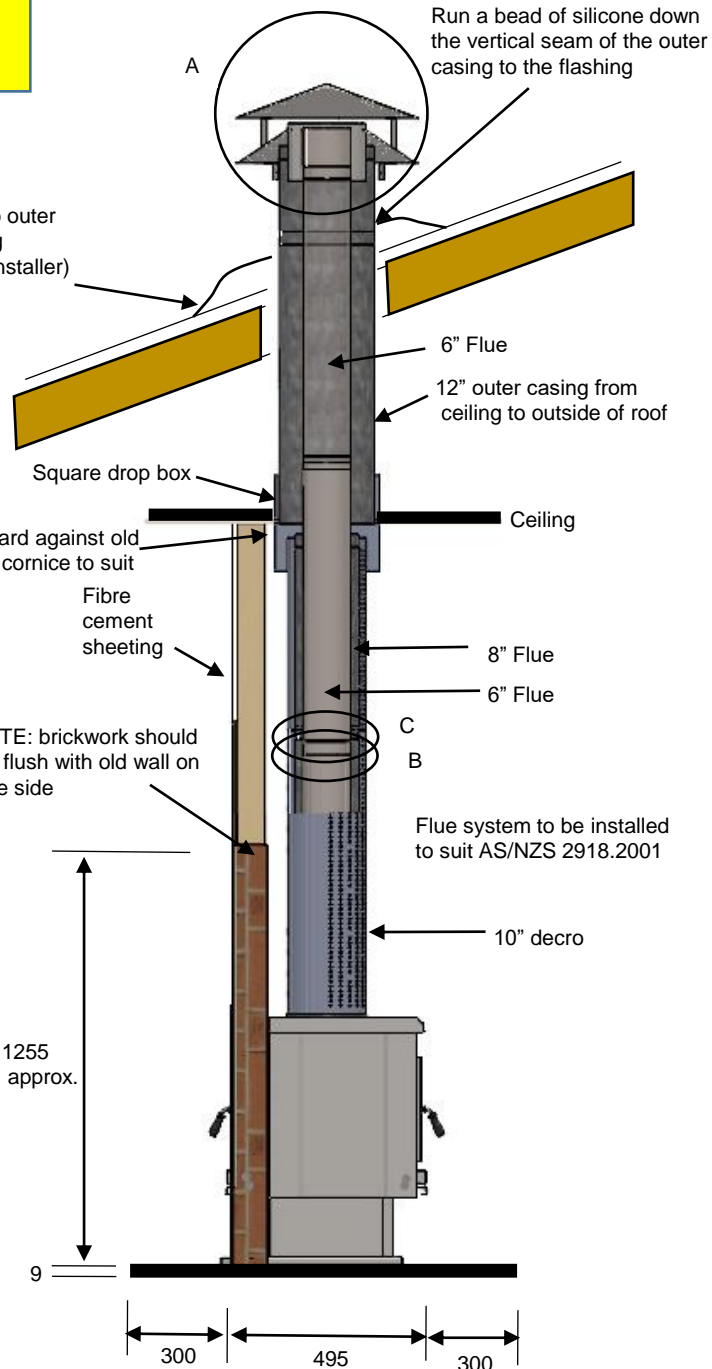
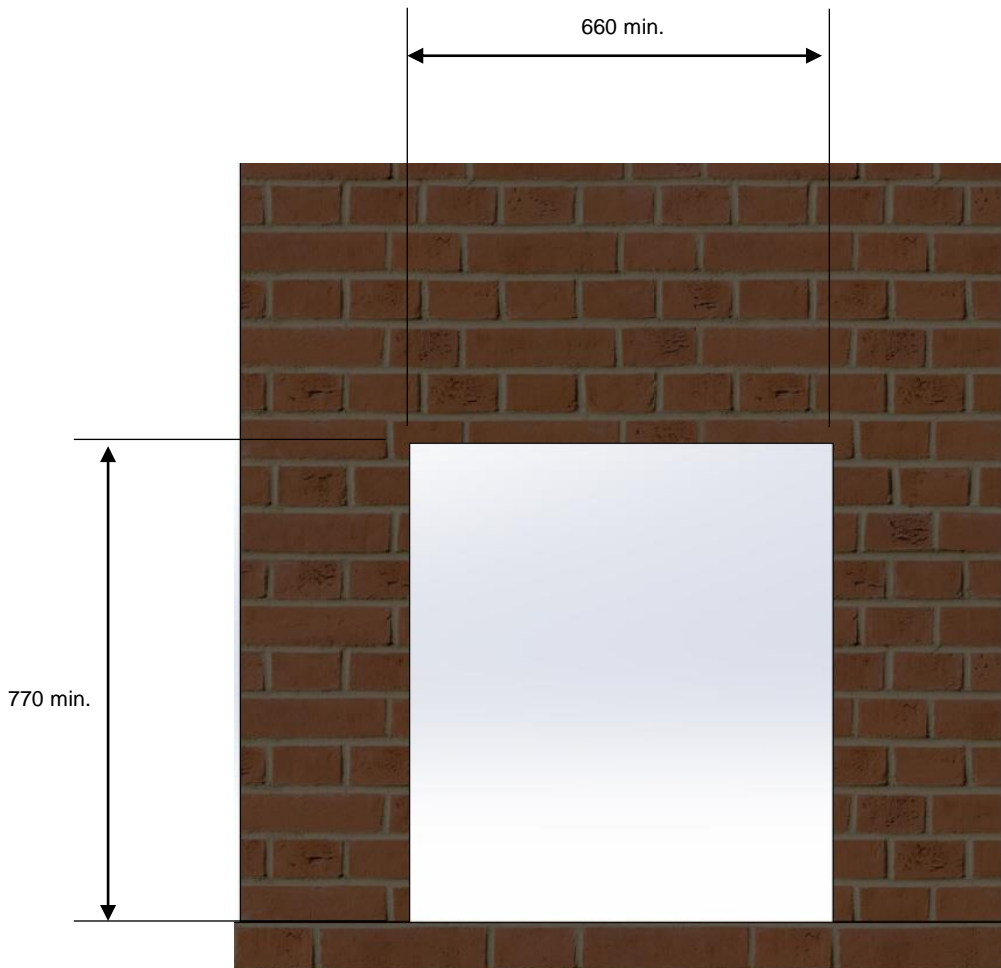

Fig. 2

INSTALLATION INSTRUCTION

COUPE WALL PENETRATION MODEL



Note: Minimum hebel / brick cut out is 660mm wide x 770mm high

INSTALLATION INSTRUCTION

COUPE WALL PENETRATION MODEL

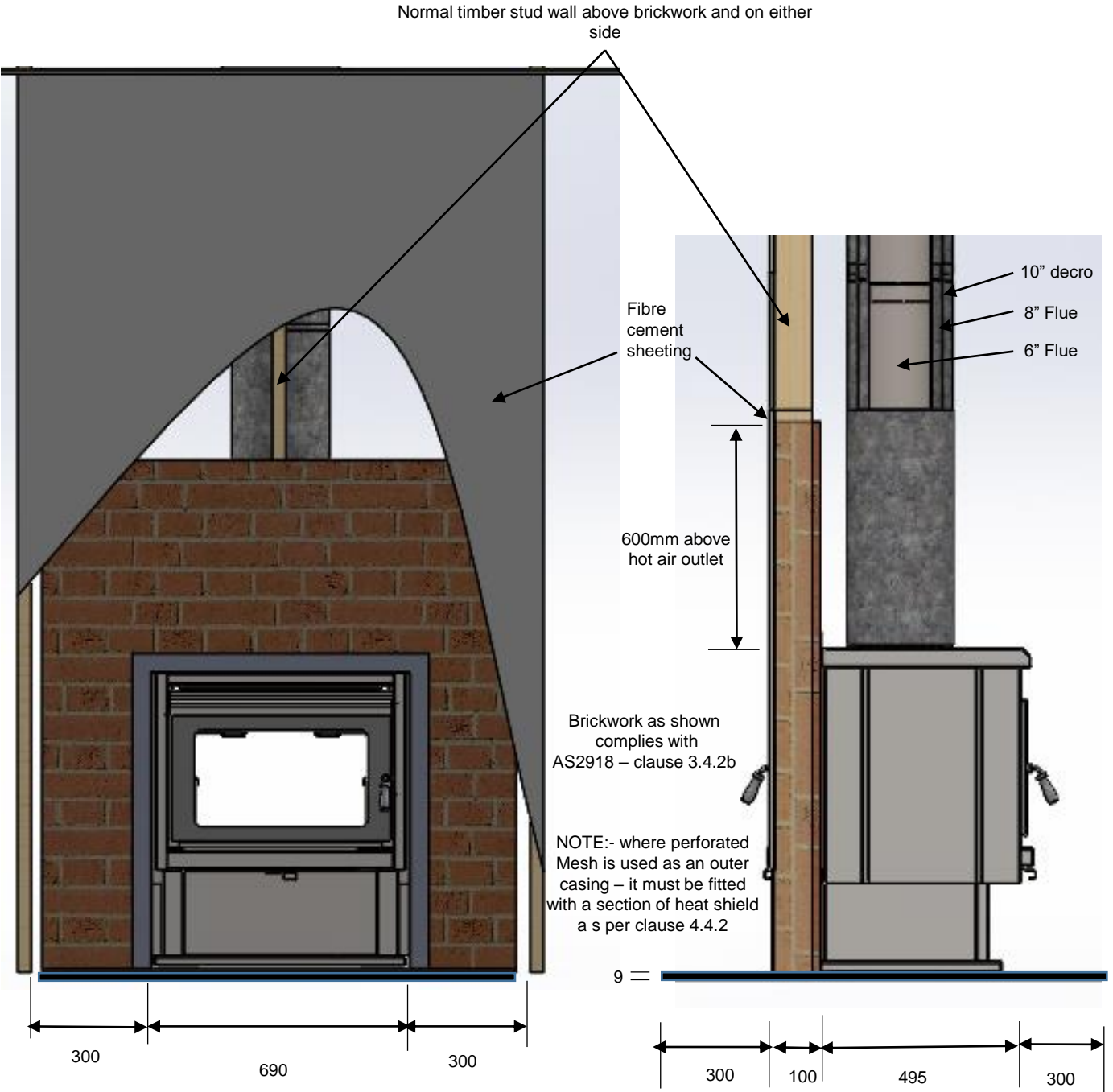

NOTE:- Non combustible material must extend 600mm above unit and 300mm either side before any combustible timber frame work is used

HEARTH DIMENSIONS

INSTALLATION INSTRUCTION

COUPE WALL PENETRATION DOUBLE BRICK CONFIGURATION

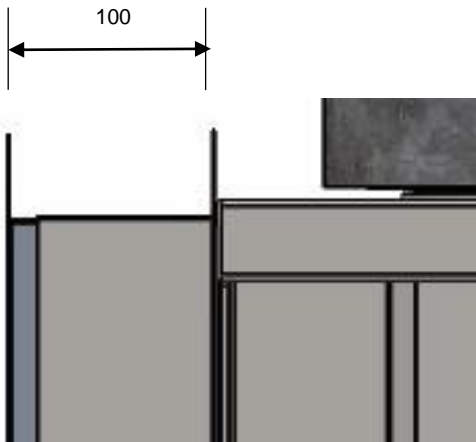
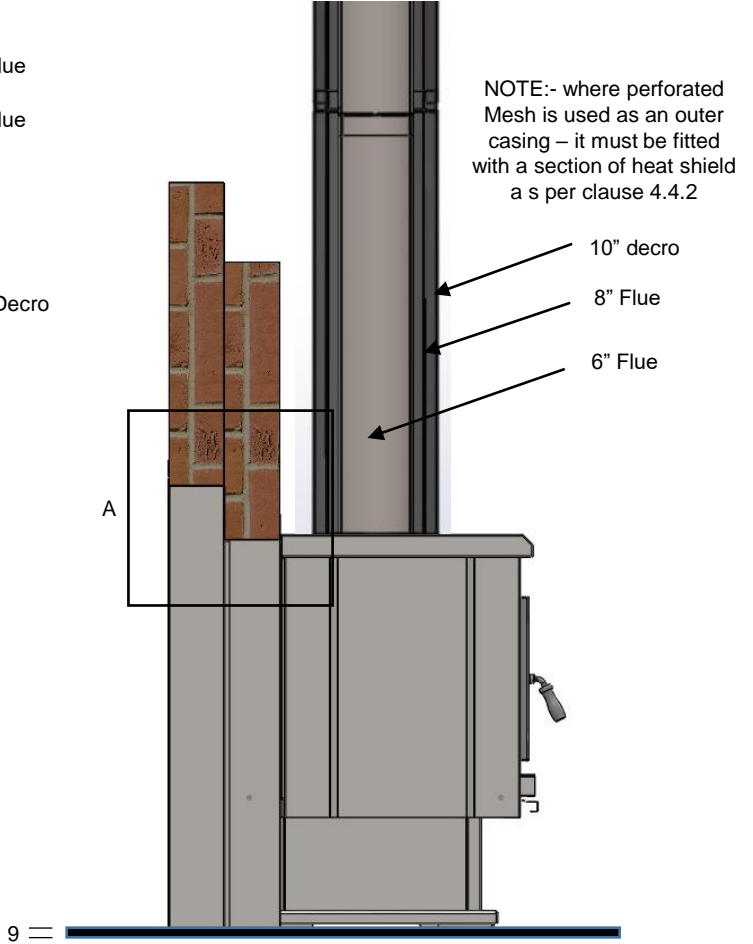
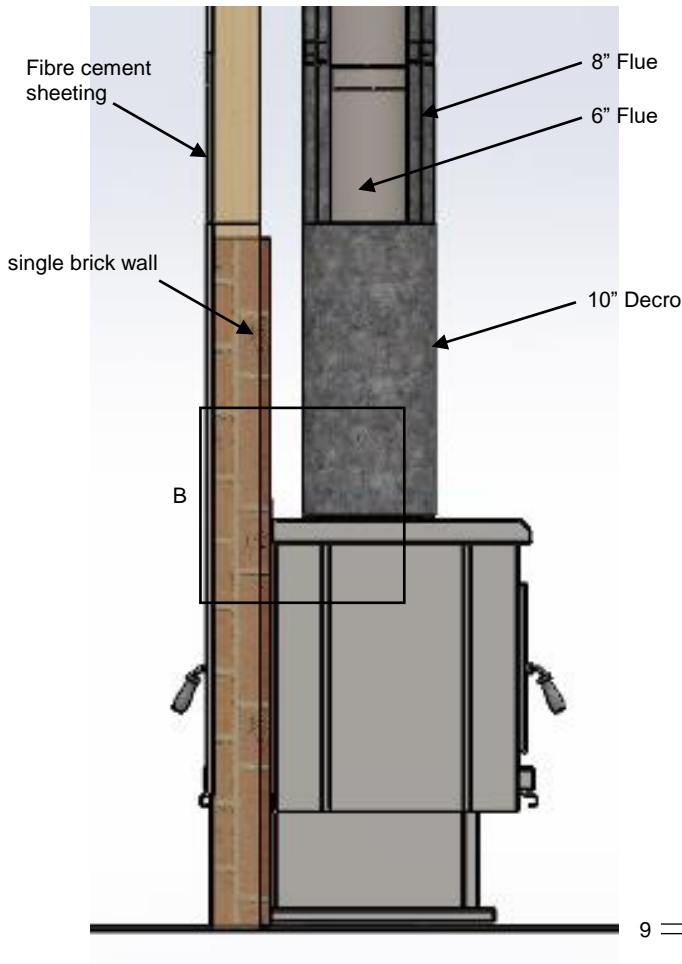

Detail A
Single brick wall omitted from view

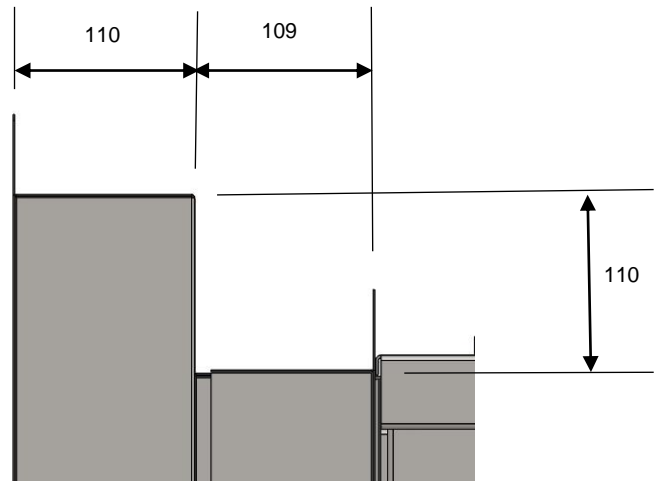

Detail A
Double brick wall omitted from view

INSTALLATION INSTRUCTIONS

MINIMUM HEIGHT OF FLUE SYSTEM EXIT INSTALLATION TO COMPLY WITH AS/NZS 2918

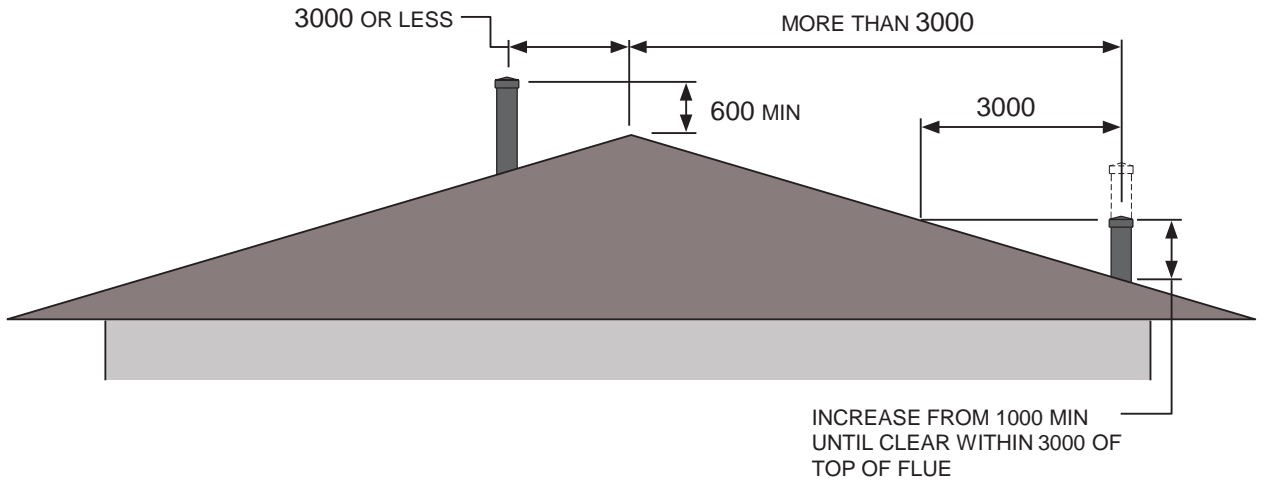
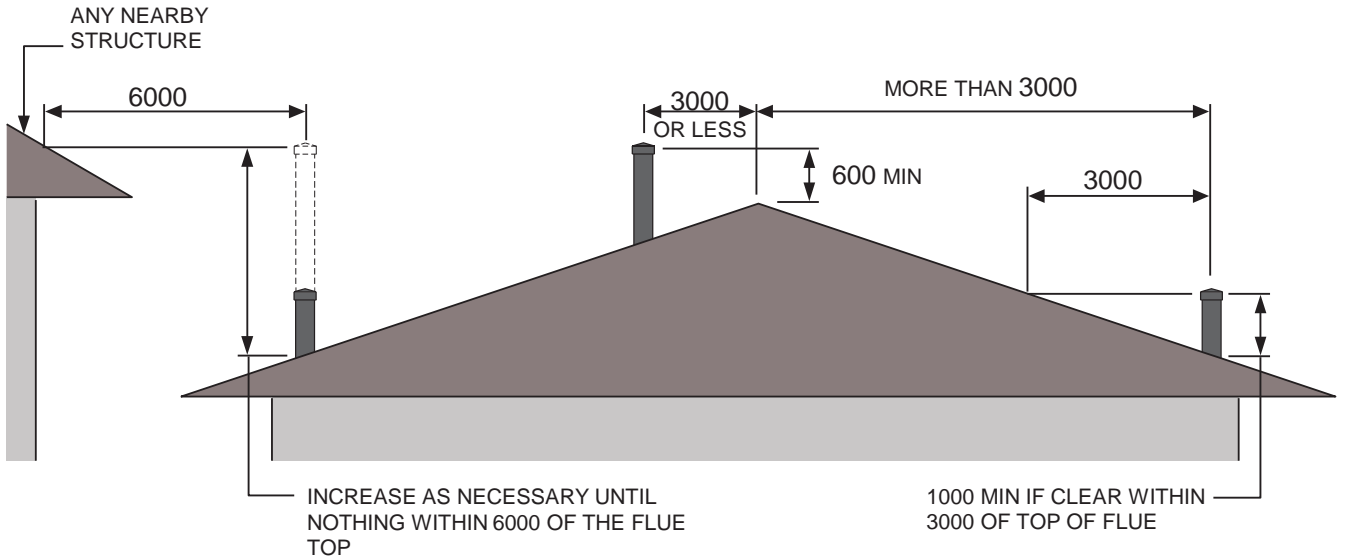

DIMENSIONS IN MILLIMETRES



Certificate of Compliance for **SOLID FUEL HEATERS**

This is to certify that the appliance stated on this certificate has been tested for Heat Output, Thermal Efficiency and Particulate Emissions in accordance with the Australian / New Zealand Standard(s) detailed below

Manufacturer	Kemlan Industries
Make	Coupe
Model	Wall Penetration Series II
Type	Inbuilt Appliance
Category	Slow combustion Wood Heater
Fuel Type	Hardwood
Test Report No:	ASFT19064-1
	HCMG/16/037
Maximum Avg Heat Output	10.3kW
Overall Avg Efficiency	63%
Particulate Emissions Factor	1.2g/kg
National Standards	AS/NZS 4012 (2014)
	AS/NZS 4013 (2014)
	AS/NZS 2918 (2018)

ASFT hereby grants to:

Kemlan Industries

of

13 French Avenue, Brendale QLD, Australia, 4500

Certificate No.:	ASFT19C075	Certified Date:	7 September 2019
Issue Date:	7 September 2019	Expiry Date:	8 August 2024

Steve Marland

Managing Director of ASFT

ASFT is an accredited laboratory by the National Association of Testing Authorities (NATA accreditation No. 20042) for compliance with ISO/IEC 17025. ASFT performs compliance testing of Solid Fuel Appliances to the relevant Australian/New Zealand standards under this Accreditation. This activity is coupled with periodic surveillance of the certified product taken from the market place or the manufacturer's factory. This certification is subject to the conditions set forth in the characteristics below and is not to be construed as any recommendation, assurance or guarantee by ASFT of the product acceptance by Authorities having jurisdiction.

Australian Solid Fuel Testing, 3 Garden Street, Morwell, Victoria, Australia 3840
ABN 46 610 154 768

KEMLAN INDUSTRIES

Operating Instructions

Congratulations on the purchase of your Australian made Kemlan slow combustion wood fireplace.

We hope this serves you well, not just as a stunning feature; but as a functional tool for heating your home and keeping you and your family warm however cold the winters may get, because this is what Kemlan specialises in and has perfected, making fires in Brisbane QLD since 1969, 'Australian made for Australian conditions'.

Welcome to the Kemlan family.

I would like to share with you the correct way to operate your Kemlan wood fire giving best results for both heating and useability.

Let's get started:

The First Burns -

Unfortunately, we have no control over how the fire is loaded nor do we have any control over what quality of fuel / timber is used, therefore we can only give recommendations, and this will be the difference in heat output and length of burn.

Hard wood should always be used as the main fuel source in all Kemlan wood heaters at a moisture level of between 12% - 20% (always have a moisture meter).

If the timber is too dry it will burn faster, if the timber is too wet it will struggle to burn at all and give very little heat.

The first few burns in a wood fire are commonly referred to as 'curing burns', this is when you are getting heat into the appliances steel and paint for the first time.

What we are trying to achieve here is 3-fold:

The **first** goal is to get heat into the white ceramic baffles and the steel flue system, getting these 2 things hot will create the 'draw' of the fireplace this is the process in which the smoke is drawn out of the fireplace chamber through the flue system.

The **second** goal is to lay a bed of ash in the base of the fire, ash in the bottom of the fire is essential to the performance of the fireplace, the optimal thickness of ash is 2-3 Inches (25mm - 75mm).

Having this bed of ash will assist the fuel to light easier creating an air layer under the timber, it will also assist in a longer hotter burn as the ash holds a large amount of the heat while the timber above is burning. So DO NOT clean your ash out until you have to, you should never see the firebricks in the base of your fire.

The **third** goal of the initial burns is to cure the paint on the fireplace casing, Kemlan fires are painted with a high temperature paint. When first applied at our factory, the paint is very soft, we place all finished fireplaces under heat lamps to start the 'curing' process but because of the time it takes and

the temperature the casing needs to stay at to complete this process we need YOU to finish this cure in your home by lighting your new fire! So, let's do it!.....

Building your fire -

Whether you have purchased a small, medium or large chamber fireplace the set-up is the same.

Kemlan introduce more primary air into the chamber of the fireplace than most other brands on the market, this makes it very easy to light the fire from a cold start, it also makes it easy for you the user of the fireplace to load the paper or firelighters, kindling (small pieces of soft wood) and hard wood into the chamber straight away.

Your goal should be to fill the fireplace chamber front to back, sided to side to make sure heat is evenly distributed throughout the entire firebox.

We don't want to have to keep tending to the fireplace slowly adding pieces of timber and constantly opening the door, one full load of timber is far better.

Scan the QR code below to access the 'How to stack and light your Kemlan wood fire' video.

Please take some time to watch to see if your process is the same.



Now your Kemlan fire is up and running make sure to keep the primary air slide fully open, this will ensure maximum oxygen is getting to the fuel and this will create quicker heat into the fireplace box, baffle, flue and of course your home.

The air slide can move from extreme left (fully open) to extreme right (fully closed).

Think of this slide like an accelerator and brake on a car. Fully open would be putting your foot down on your car's accelerator, fully closed is like putting the breaks on in the car.

When we want energy into the room (KW) we want the slide open, as the room gets to the desired temperature the air slide can be moved towards the right-hand side reducing the air to the chamber slowing the energy output and fuel consumption.

The air slide should only be moved half to $\frac{3}{4}$ of the way across while you can still tend to the fire, closing it completely or starving the fire should only be done when you cannot tend to the fire for long periods of time (e.g. going to bed) when your only goal is for length of burn.

Remember no matter whether it is a curing burn or an everyday use, heat is key, never light a small fire! A small fire in a large, chambered firebox will not produce any heat in the components of the fireplace or in your room. Choose the fire that best suits your living and heating requirements.

Reloading your Kemlan fire -

When it is time to add timber to your fireplace firstly make sure the underside of your white baffles is actually white, if they are still black this will mean the hardwood has not fully caught alight. If this is the case wait, you will notice as the fire heats up and your seasoned hardwood is fully lit the baffle plates will return to their original white condition, this means the fire drawing correctly through the flue system and burning cleanly with the secondary air in full swing.

You can now open the air slide fully, crack the door slightly allowing the air pressure to equal then carefully fully open the door.

Have the timber you are going to load in the chamber ready to immediately reload, be prepared, don't open the door and then go looking for the optimal pieces of timber, the longer you wait the colder the chamber will get and the higher the chance of smoke coming back into the room.

Overnight burns -

All medium and large size Kemlan fireplaces have what is called an 'overnight burn' but what does this mean??

Like we have touched on above, the air slide should only be shut down fully when you want extended length of burn, as soon as you starve the firebox of air the fire will burn dirtier and heat output will be greatly reduced, in some instances the glass will blacken due to the lack of air movement inside the chamber. The black creosote will burn off the glass when the fire's air control is back up to high with a new load of timber.

Generally, a Kemlan medium to large chamber will burn between 8 - 12 hours depending on the quality of fuel/timber and how full you stack the chamber. For maximum burn time you would fill the chamber up to 50mm below the secondary air tubes underneath the white baffle plate. The larger the pieces of timber the better!

After the 8-12 hours you should still have glowing embers in the base of the fire, a small amount of kindling and medium size pieces of hardwood can then be re-loaded making sure the air control has been moved back to 'full left' introducing maximum primary air again.

If you follow these simple steps, you will find your Kemlan fireplace is one of the best investments you have made to your home.

From everyone in Kemlan we thank you for your business and wish you a lifetime of warmth and enjoyment.

IMPORTANT:

UNDER NO CIRCUMSTANCES SHOULD ANY SOLVENTS SUCH AS METHYLATED SPIRITS, PETROL, MINERAL TURPENTINE ETC OR DETERGENTS, BE ALLOWED TO COME IN CONTACT WITH THE PAINTED SURFACE OF THE HEATER AS DAMAGE TO THE FINISH WILL RESULT. IF AN ACCIDENT DOES OCCUR, SPRAY CAN PAINT IS AVAILABLE FROM YOUR NEAREST KEMLAN DEALER.

WARRANTY

1. Kemlan wood heaters carry a warranty on the 6mm firebox for a period of ten (10) years.
2. This warranty also covers other components of the heater for a period of one (1) year. These components include the baffle plate, handle assembly, secondary air tubes and fan.
3. Kemlan's warranty covers the wood heaters against defects in materials and manufacture.

4. THIS WARRANTY DOES NOT COVER –

- 4.1 Failure to comply with manufacturer's operation instructions.
- 4.2 Normal wear and tear or damage caused by incorrect installation.
- 4.3 Any form of rust and/or corrosion to the painted finish of the heater.
- 4.4 Damage to the glass in the door, if the damage is caused by impact or misuse.
- 4.5 The cost of collection and delivery of the wood heater and/or parts.
- 4.6 Damage caused by water ingress.
- 4.7 Cost of removal of defective heater or re-installation of replacement heater.
- 4.8 Failure to use fireplace components supplied by Kemlan Industries Pty Ltd.
- 4.9 Cost of inspection for damaged heater.

5. CLAIMS –

- 5.1 (i) Kemlan will provide a full replacement of the heater in the first five years after installation.

(ii) Replacement in the subsequent five years (i.e. sixth to tenth year after installation will be on the following basis.
Owner will pay fifty percent of the current retail price, if the claim is made in the sixth year – tenth year after purchase.
- 5.2 Replacement of heater subject to all conditions in section four of warranty.
- 5.3 Should any defects occur, contact the Kemlan distributor from whom you purchased the heater.
- 5.4 Under this warranty the defective parts will be repaired or replaced, free of charge.
6. The fireplace installation must comply with the relevant local statutes, ordinances, regulations and by-laws.

7. THIS WARRANTY IS VOID IF:

- 7.1 The appliance has been over-fired or operated in atmospheres contaminated by chlorine, fluorine or other damaging chemicals. Over-firing can be identified by, but not limited to, warped plated or tubes, rust coloured cast iron, bubbling, cracking and discolouration of steel or enamel finishes.

PLEASE COMPLETE AND RETAIN THIS SECTION FOR YOUR RECORDS

Purchased from:
Address:
Date of Purchase: