

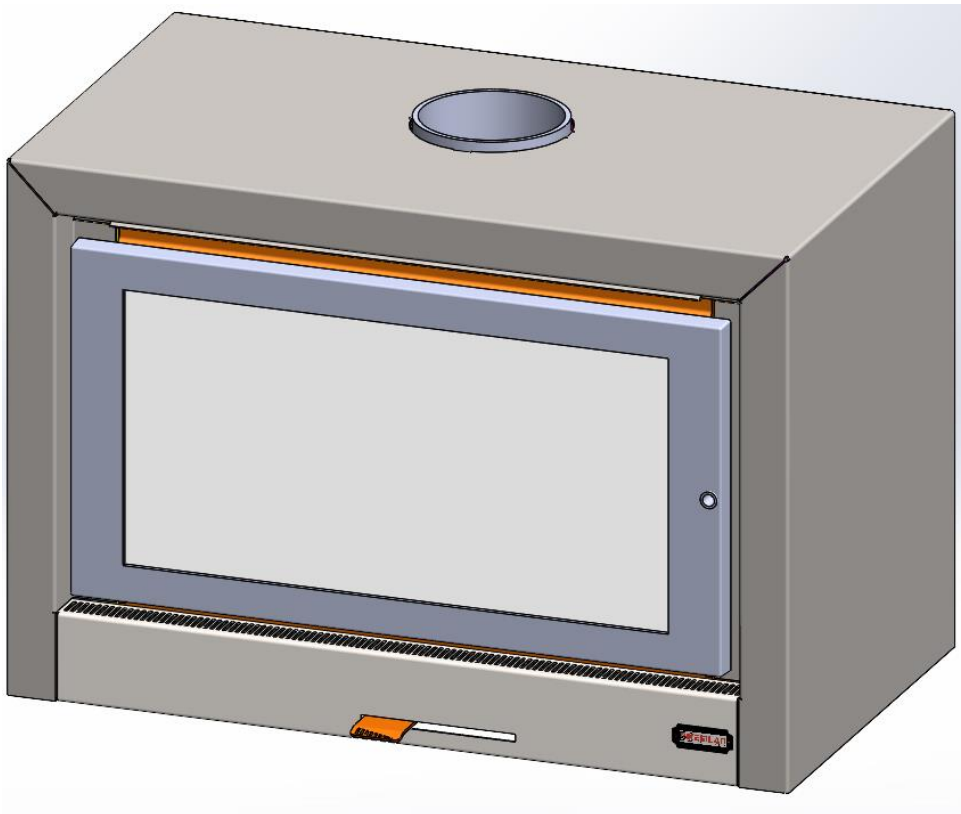

Specialists in fireplace design and manufacture

HALO 800 FREESTANDING HARDWOOD **INSTALLATION & OPERATING INSTRUCTIONS**



IMPORTANT:

INSTALLER, PLEASE LEAVE THESE INSTRUCTIONS WITH THE UNIT ON COMPLETION.

10 YEAR FIREBOX WARRANTY

**The firebox is covered by a 10 year warranty.
Other parts are covered by a one year limited warranty.**

Head Office - 13 French Avenue, Brendale, Queensland 4500
Telephone - PH: (07) 3490 5500
Facsimile - FAX: (07) 3490 5520
Website: - www.jetmaster.com.au
Business hours: - Monday to Thursday 7:30am-4:00pm. Friday 7:30am-2:00pm
Email: - sales@jetmaster.com.au

DIMENSIONS

HALO 800 FREESTANDING HARDWOOD WITH FAN

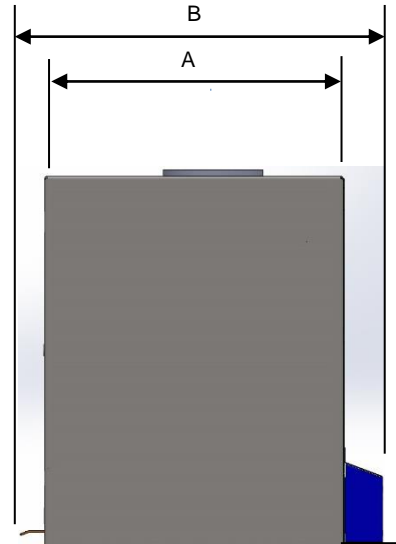
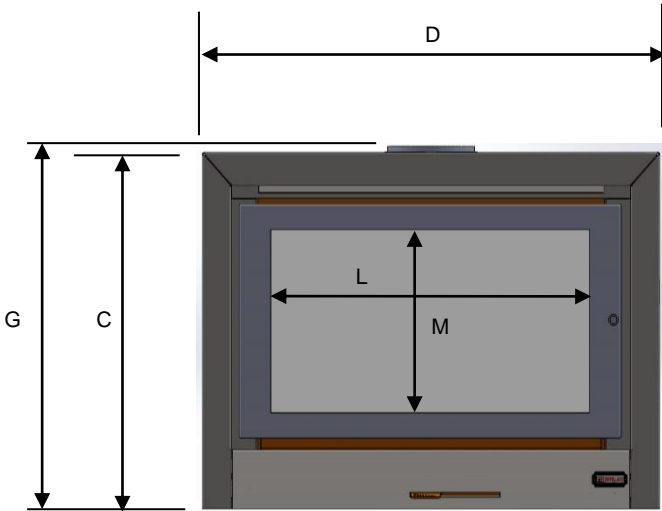
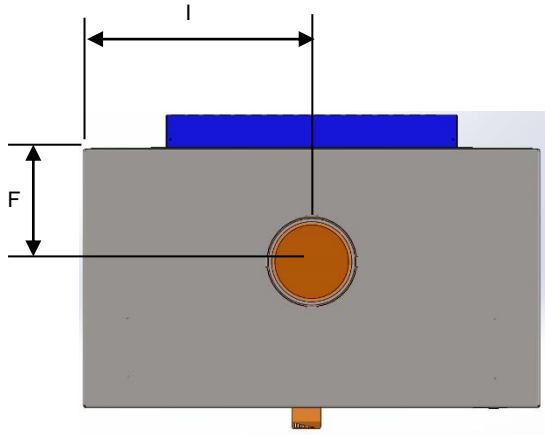

DESC.	MODEL	A	B	C	D	F	G	I	L	M
HALO 800 FS HARDWOOD	FREESTANDING	493	595	588	866	215	598	433	603	302

DIMENSIONS

HALO 800 FREESTANDING HARDWOOD CLEARANCES

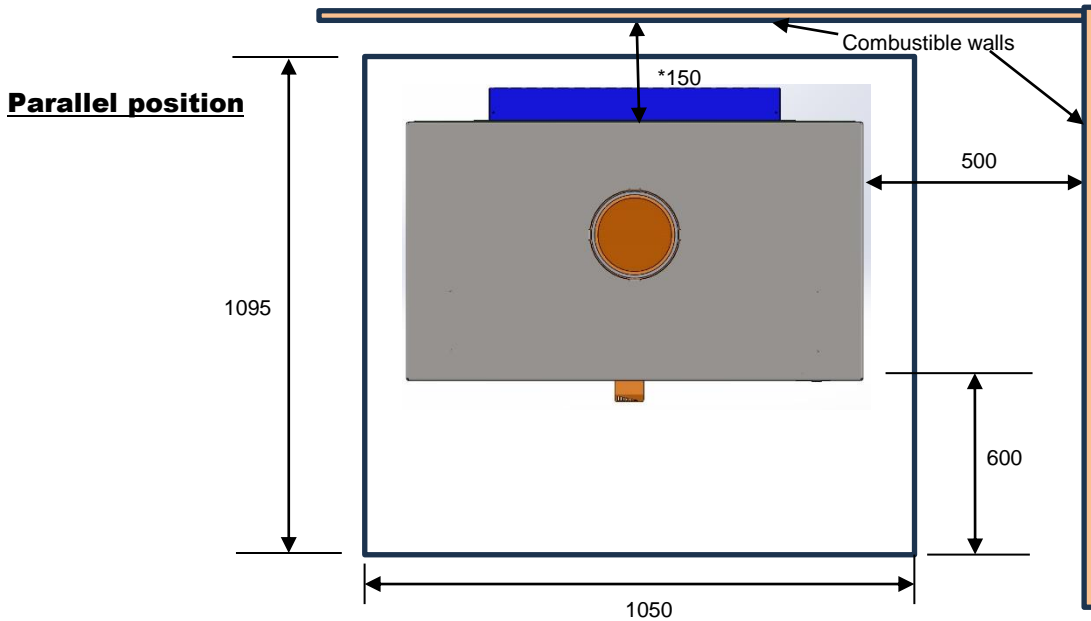

* The rear wall clearance can be 150mm from a combustible wall when installed with an additional 900mm high x 180 deg. stainless steel rear flue shield.. The rear flue shield must cover the rear of the spigot. The back clearance will be 350mm if an additional flue heatshield is not fitted

Hearth Table

UNIT H OFF GROUND	18	100	200	300	400	500
HEARTH TO EXTEND	600	590	560	520	440	300

Hearth needs to be minimum 24mm thickness non-combustible material under and in front of appliance (cement sheet or similar).

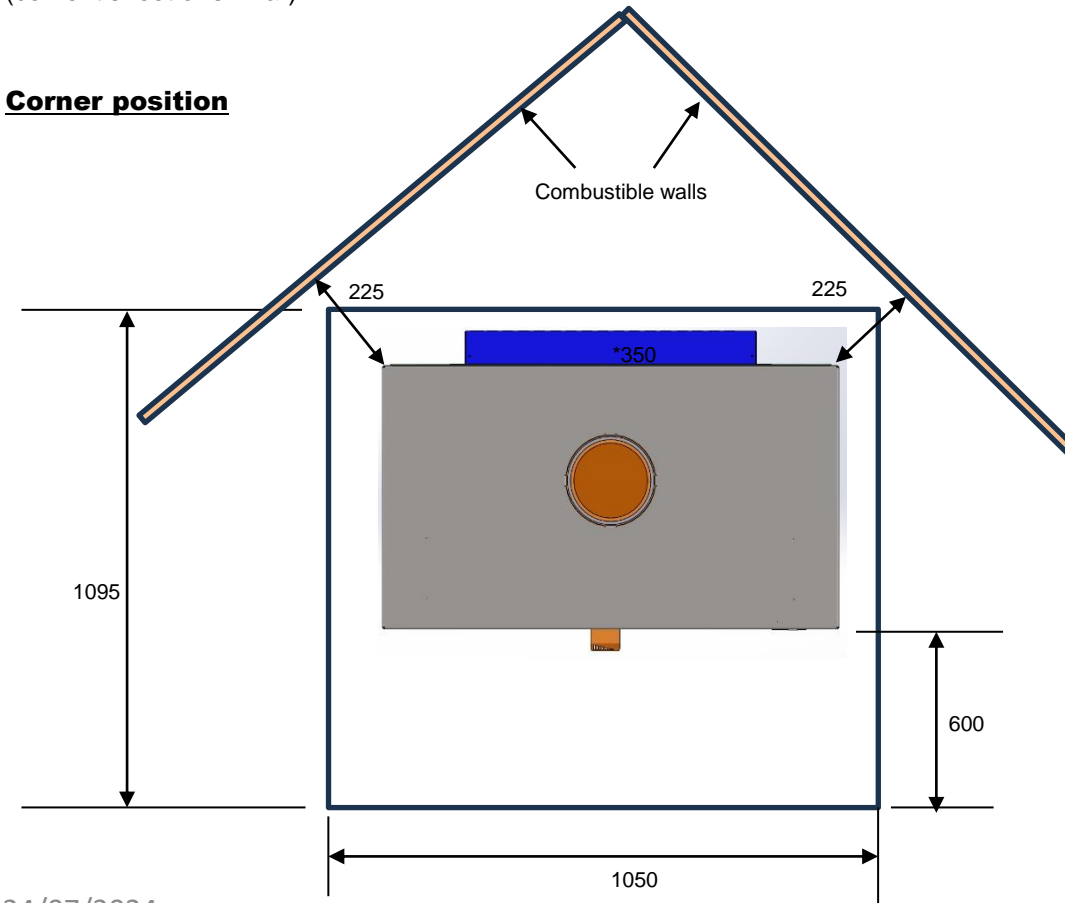

HALO 800 HARDWOOD FREESTANDING MERIDIAN BENCH MEASUREMENTS

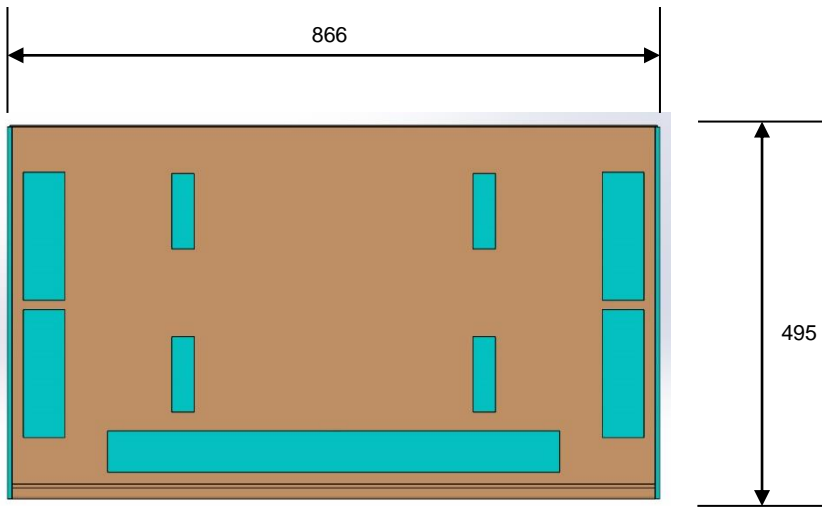

TOP VIEW

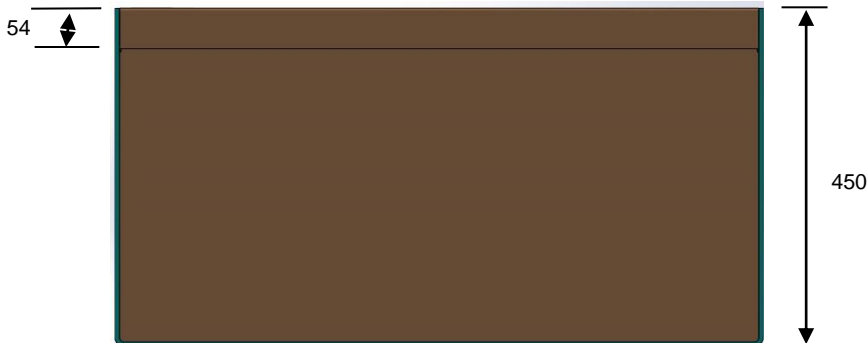

FRONT VIEW

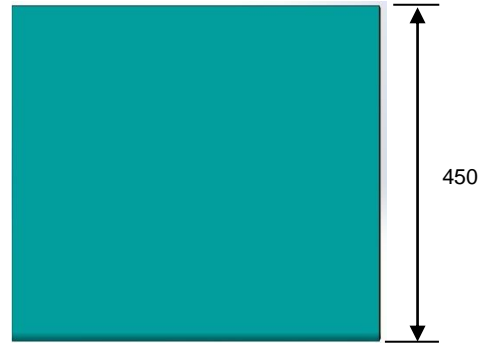

SIDE VIEW

FREESTANDING UNIT WITH HEAT SHIELD (APPENDIX F)

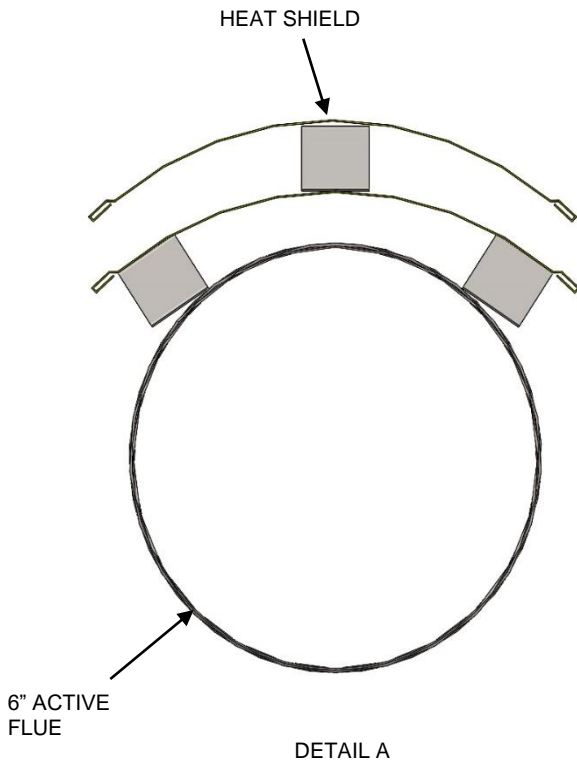

DETAIL A

THE HEAT SHIELD WILL COVER 33% OF THE TOTAL CIRCUMFERENCE OF THE ACTIVE FLUE.

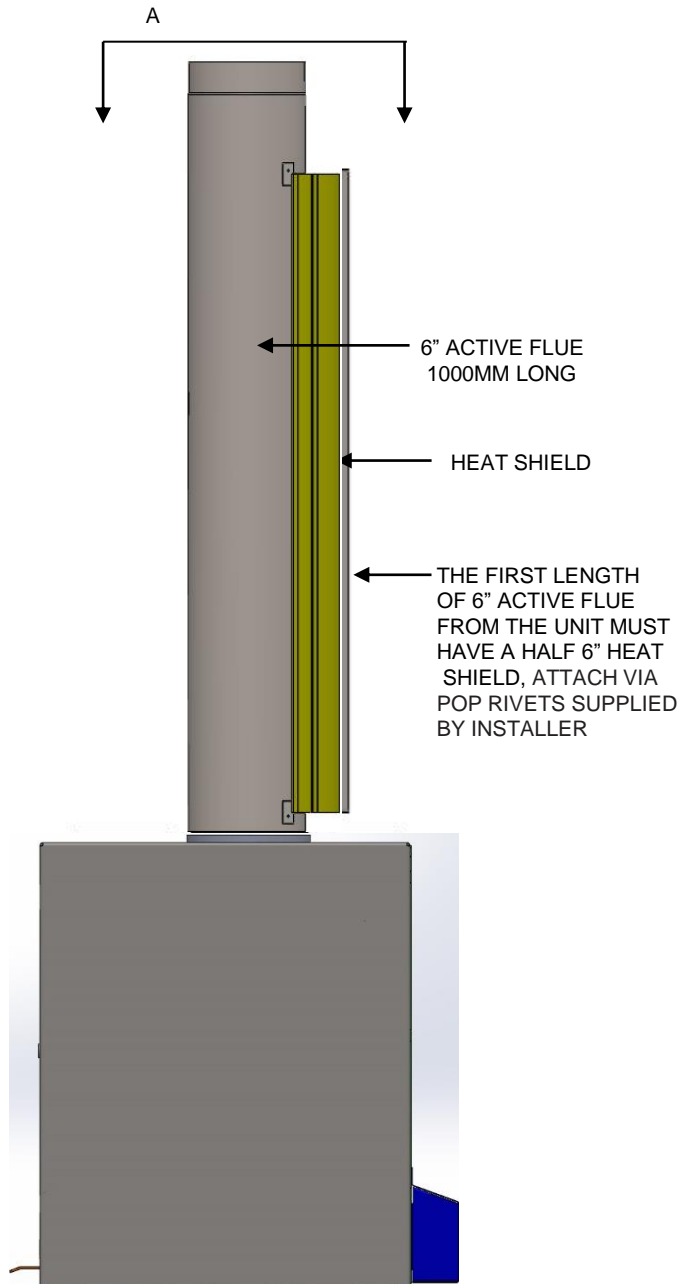

IMPORTANT:

NEW FLUE KIT ACTIVE + HALF HEATSHIELD – “ANY SINGLE HEATSHIELD CAN BE USED FROM 900MM UP TO 1200MM HEIGHT”

“THIS HEATER HAS BEEN TESTED WITH THE FAN CONNECTED TO A STANDARD 3 PIN GPO SOCKET OUTLET. THE FAN DOES NOT NEED TO BE HARD WIRED”.

IMPORTANT: ANY APPENDIX F APPROVED FLUE KITS CAN BE USED ON THESE KEMLAN FREESTANDING FIREPLACES AS LONG AS IT COMPLIES WITH THE LABORATORY TESTED HEAT SHIELDING”

FREESTANDING FLUE KIT (APPENDIX F)

- 2 – 6” STAINLESS STEEL FLUE 1000mm CRIMPED**
- 2 - 6” STAINLESS STEEL FLUE 1000mm CRIMPED, BLACK**
- 1 – 8” GALVANISED FLUE 1000mm PLAIN**
- 1 – 8” GALVANISED FLUE 1000mm CRIMPED**
- 1 – 10” GALVANISED FLUE 1000mm PLAIN**
- 1 - 10” DROP BOX, 6”-10” VENTED CAP,
CRIMPED, BLACK**
- 1 - 6” HEATSHIELD BLACK**
- 2 – ANGLE BRACKETS GALVANISED
1200x50x50mm**
- 1 – 10” ROUND CEILING TRIM, BLACK**
- 1 – 10” RAKED CEILING TRIM**
- 1 – 6” – 10” DOUBLE CONE COWL**
- 1 – SPACING KIT**
- 1 – INSTALLATION INSTRUCTION**

FREESTANDING UNIT WITH HEAT SHIELD (DECRO 8")

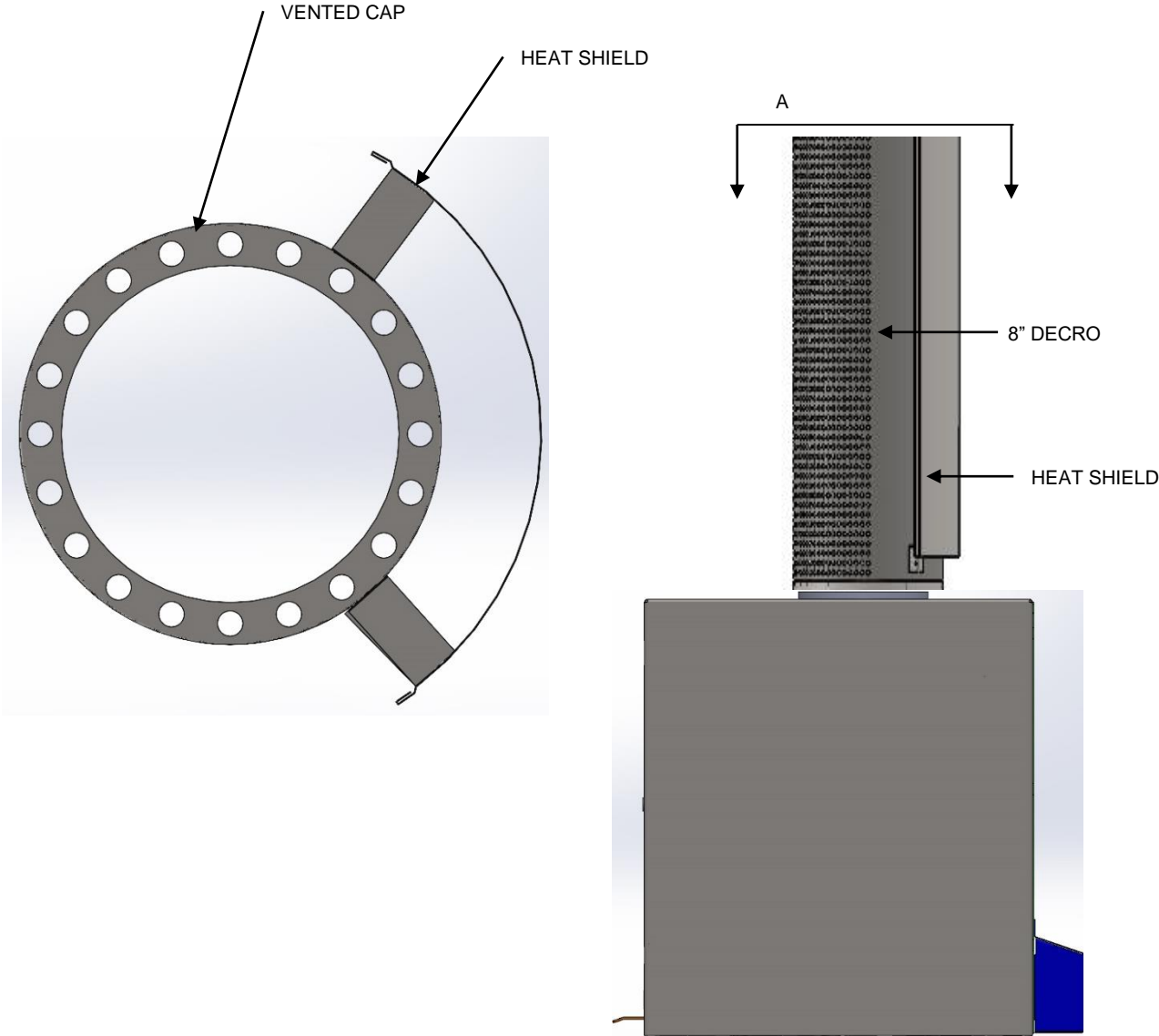

FREESTANDING DECRO FLUE KIT

- 3 – 6” STAINLESS STEEL FLUE 1000mm CRIMPED**
- 1 – 6” STAINLESS STEEL FLUE 1000mm CRIMPED/SWAGED**
- 2 – 8” GALVANISED FLUE 1000mm PLAIN/CRIMPED**
- 1 – 10” GALVANISED FLUE 1000mm PLAIN**
- 1 - 10” DROP BOX, 8”-10” VENTED CAP,
CRIMPED, BLACK**
- 1 – DECROSHIELD (A) 8” -900mm (WITH HEATSHIELD)
BLACK**
- 1 - DECROSHIELD (E) 8” -900mm (WITH HEATSHIELD)
BLACK**
- 2 – ANGLE BRACKETS GALVANISED
1200x50x50mm**
- 1 – ADDITIONAL HEATSHIELD**
- 1 – 10” ROUND CEILING TRIM, BLACK**
- 1 – 10” RAKED CEILING TRIM BLACK**
- 1 – 6” – 10” DOUBLE CONE COWL**
- 1 – SPACING KIT**
- 1 – INSTALLATION INSTRUCTION**

HALO 800 HARDWOOD **BAFFLE PLATE / AIR TUBE** **INSTALLATION INSTRUCTION**

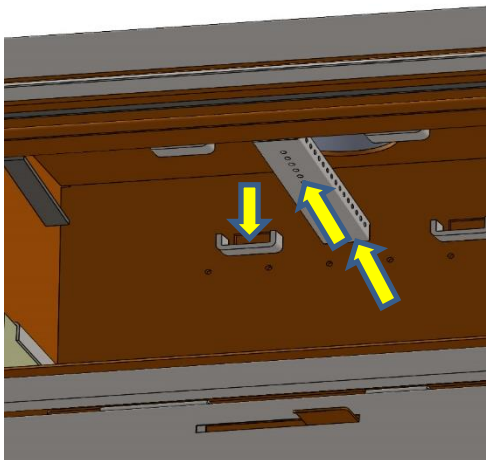

1. Install the first air tube by pushing it up, over and into the air tube holders. Make sure the air tube end with no cap is installed towards the back.

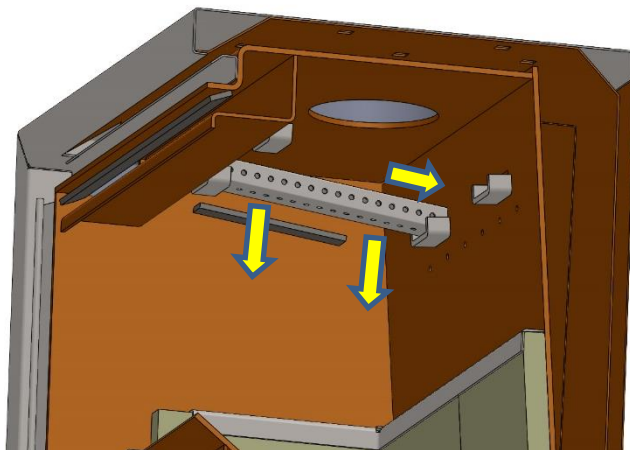

2. All air tube holes must point to sides and bottom of the appliance. Push the air tube as far back as possible.

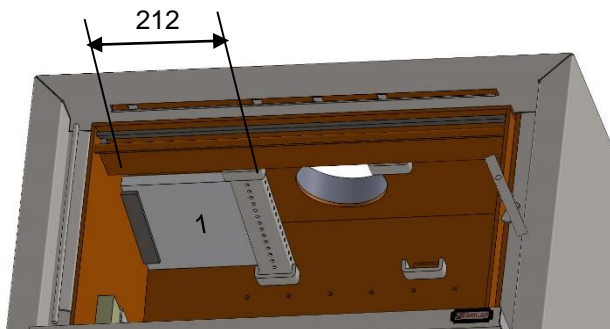

3. Place baffle plate (1) on top of the air tube, 212mm left to right, 200mm front to back, push baffle plates as far back as possible

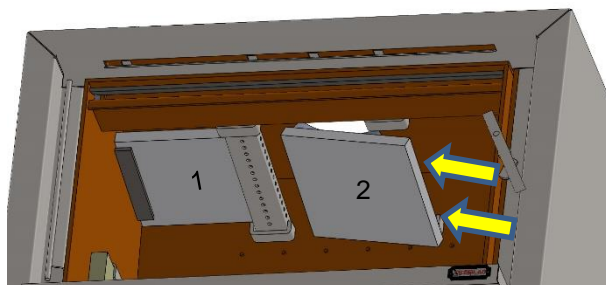

4. Position baffle plate (2) on top of baffle plate (1).

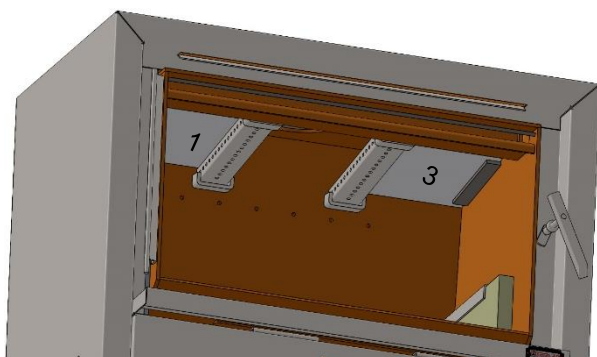

5. Install air tube and baffle plate (3) as per figure (3), this time install the baffle plates opposite side to the first one.

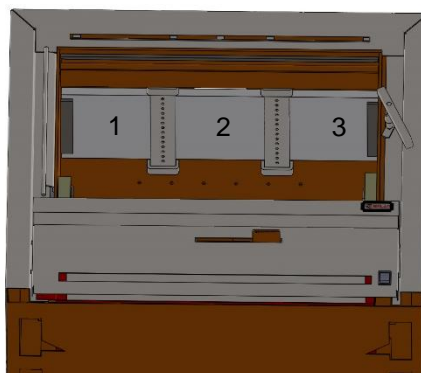

6. The final step is to install the baffle plate (2) that has been placed on top of baffle plate (1). Lower baffle plate (2) into the gap and push towards the back. The assembly is now complete.

HALO 800 FAN ASSEMBLY INSTALLATION INSTRUCTION

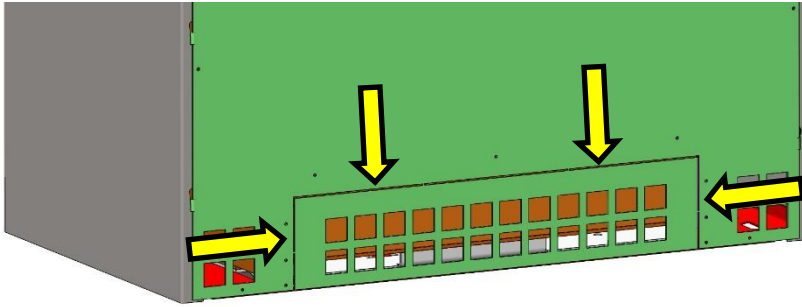

1. Break the tabs on the rear panel where indicated. Use a flat-head screwdriver to aid in breaking tabs if required and twist panel until the tabs are broken. Remove the panel from the box. Unscrew the Tek screws and set aside for re-use.

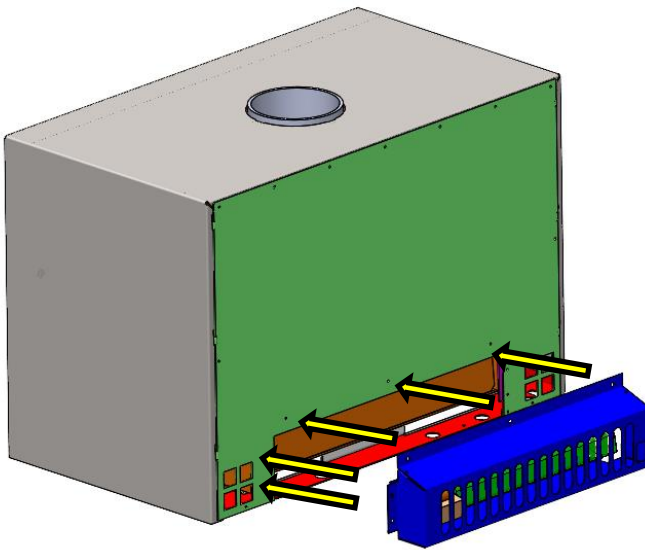

2. Use the rear panel holes as a guide to attach the fan box. Re-use the supplied Tek screws that were set aside. Make sure the electrical cord is not caught in the fan assembly.

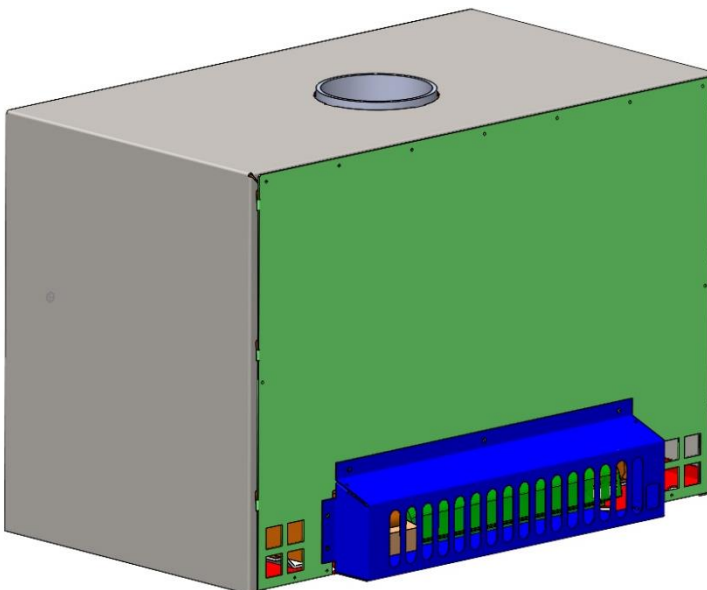

3. Plug and test the fan to make sure it is working. This will complete the fan assembly installation.

INSTALLATION INSTRUCTIONS

MINIMUM HEIGHT OF FLUE SYSTEM EXIT INSTALLATION TO COMPLY WITH AS/NZS 2918

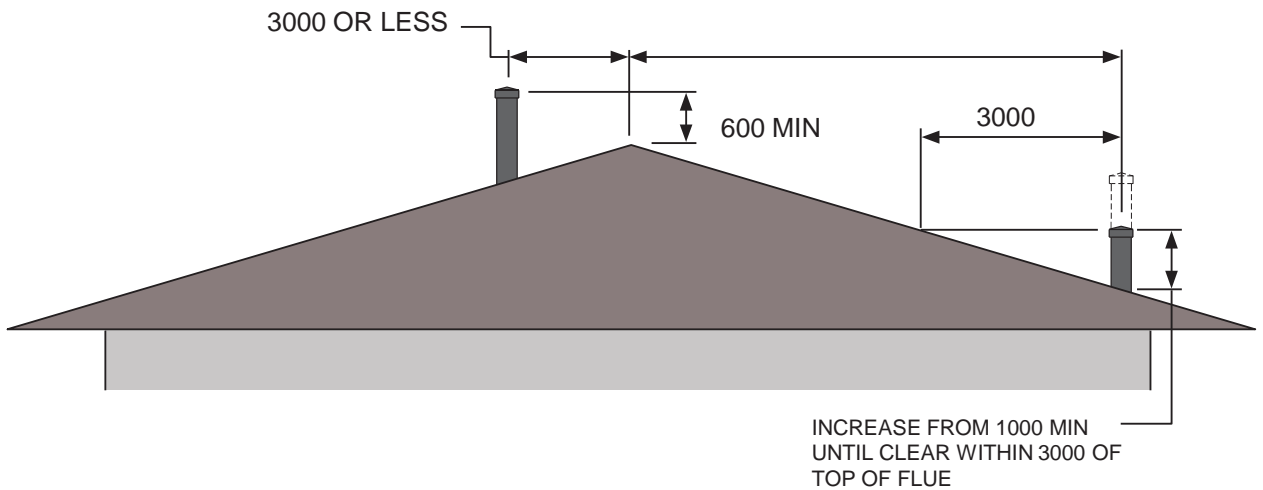
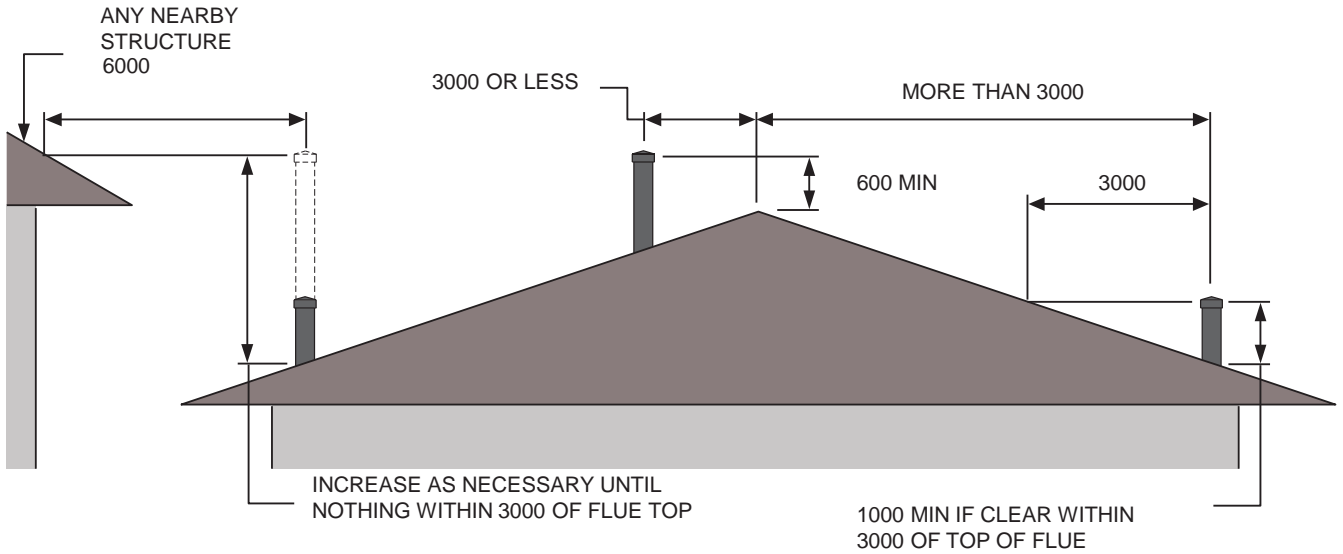

INSTALLATION INSTRUCTION

HALO 800 FLAT CEILING INSTALLATION

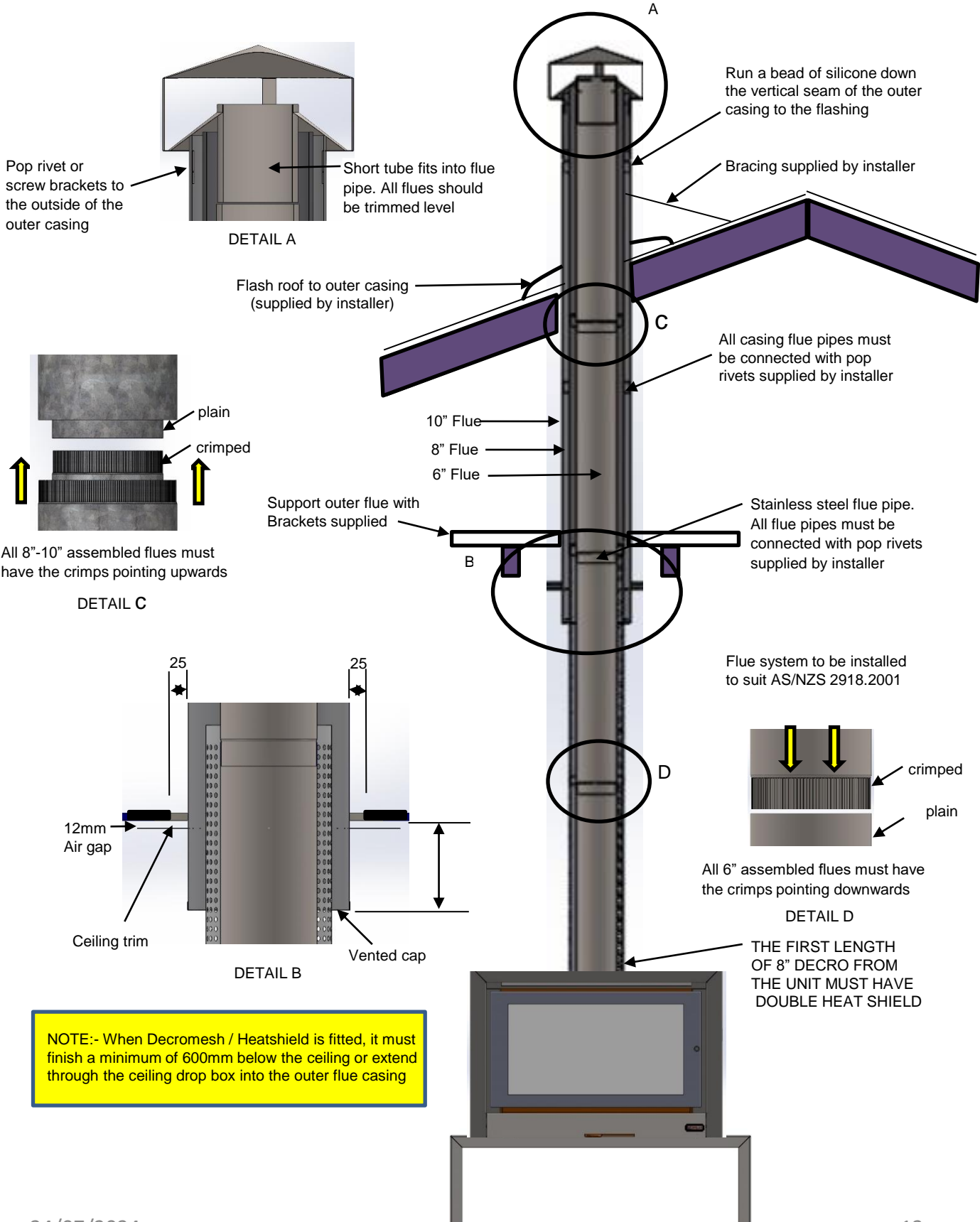

INSTALLATION INSTRUCTION

HALO 800 RAKED CEILING INSTALLATION

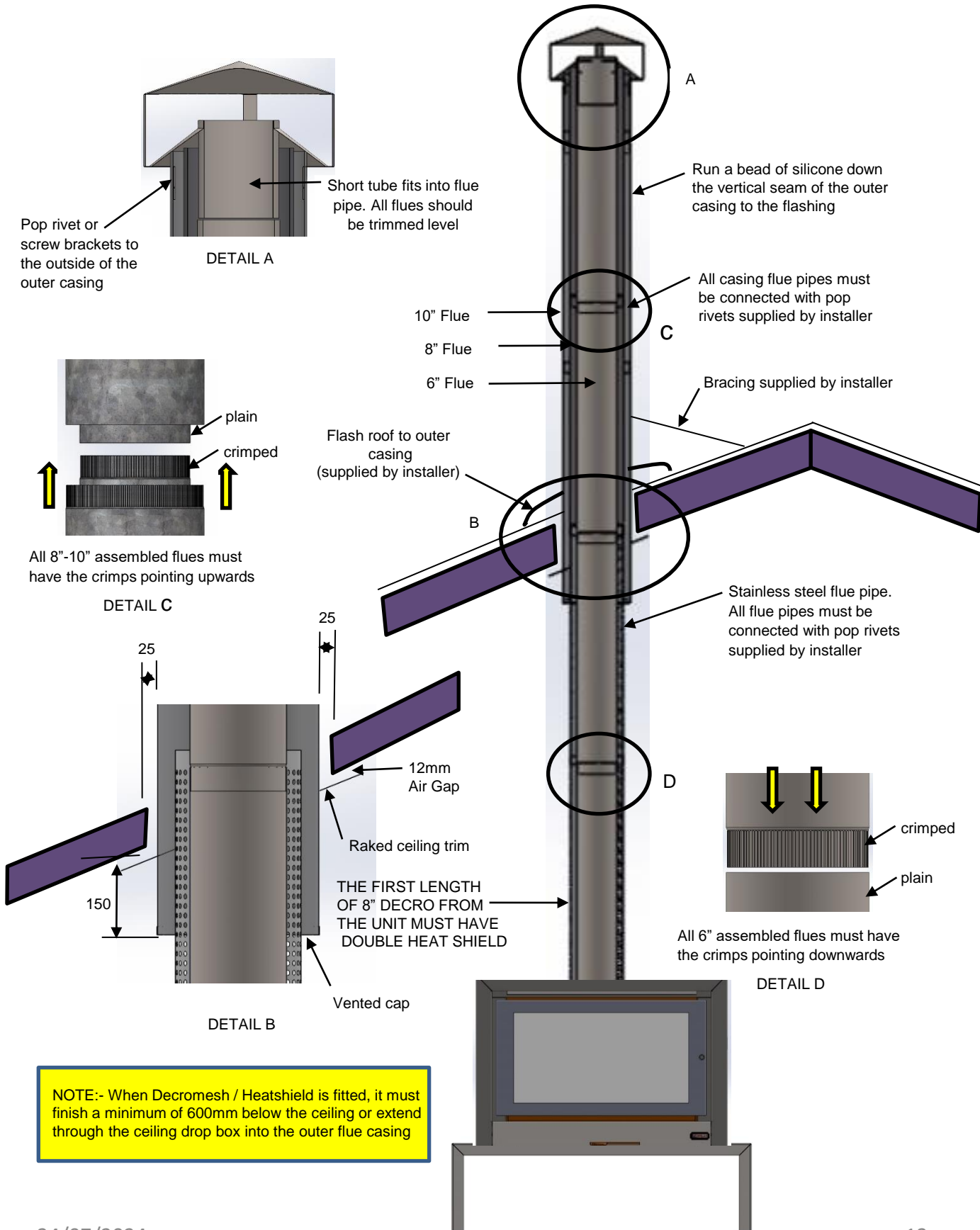

Operating Instructions

Congratulations on the purchase of your Australian-made Kemlan slow-combustion wood fireplace.

We hope this serves you well, not just as a stunning feature; but as a functional tool for heating your home and keeping you and your family warm however cold the winters may get, because this is what Kemlan specialises in and has perfected, making fires in Brisbane QLD since 1969, 'Australian made for Australian conditions'.

Welcome to the Kemlan family.

I would like to share with you the correct way to operate your Kemlan wood fire giving the best results for both heating and useability.

Let's get started:

The First Burns –

Unfortunately, we have no control over how the fire is loaded nor do we have any control over what quality of fuel/timber is used, therefore we can only give recommendations, and this will be the difference in heat output and length of burn.

Hardwood should always be used as the main fuel source in all Kemlan wood heaters at a moisture level of between 12% - 20% (always have a moisture meter).

If the timber is too dry it will burn faster, if the timber is too wet it will struggle to burn at all and give very little heat.

The first few burns in a wood fire are commonly referred to as 'curing burns', this is when you are getting heat into the appliances' steel and paint for the first time.

What we are trying to achieve here is 3-fold:

The **first** goal is to get heat into the white ceramic baffles and the steel flue system, getting these 2 things hot will create the 'draw' of the fireplace this is the process in which the smoke is drawn out of the fireplace chamber through the flue system.

The **second** goal is to lay a bed of ash in the base of the fire, The ash in the bottom of the fire is essential to the performance of the fireplace, the optimal thickness of ash is 2-3 Inches (25mm – 75mm).

Having this bed of ash will assist the fuel to light easier creating an air layer under the timber, it will also assist in a longer hotter burn as the ash holds a large amount of the heat while the timber above is burning. So **DO NOT** clean your ash out until you have to, you should never see the firebricks in the base of your fire.

The **third** goal of the initial burns is to cure the paint on the fireplace casing, Kemlan fires are painted with a high-temperature paint. When first applied at our factory, the paint is very soft, we place all finished fireplaces under heat lamps to start the 'curing' process but because of the time it takes and

the temperature the casing needs to stay at to complete this process we need YOU to finish this cure in your home by lighting your new fire! So, let's do it!.....

Building your fire –

Whether you have purchased a small, medium or large chamber fireplace the set-up is the same.

Kemlan introduces more primary air into the chamber of the fireplace than most other brands on the market, this makes it very easy to light the fire from a cold start, it also makes it easy for you the user of the fireplace to load the paper or firelighters, kindling (small pieces of Hardwood) and Hardwood into the chamber straight away.

Your goal should be to fill the fireplace chamber front to back, side to side to make sure heat is evenly distributed throughout the entire firebox.

We don't want to have to keep tending to the fireplace slowly adding pieces of timber and constantly opening the door, one full load of timber is far better.

Scan the QR code below to access the 'How to stack and light your Kemlan wood fire' video.

Please take some time to watch to see if your process is the same.



Now your Kemlan fire is up and running make sure to keep the primary air slide fully open, this will ensure maximum oxygen is getting to the fuel and this will create quicker heat into the fireplace box, baffle, flue, and of course your home.

The air slide can move from extreme left (fully open) to extreme right (fully closed).

Think of this slide like an accelerator and brake on a car. Fully open would be putting your foot down on your car's accelerator, fully closed is like putting the brakes on in the car.

When we want energy into the room (KW) we want the slide open, As the room gets to the desired temperature the air slide can be moved towards the right-hand side reducing the air to the chamber and slowing the energy output and fuel consumption.

The air slide should only be moved half to $\frac{3}{4}$ of the way across while you can still tend to the fire, closing it completely or starving the fire should only be done when you cannot tend to the fire for long periods of time (e.g. going to bed) when your only goal is for the length of burn.

Remember no matter whether it is a curing burn or an everyday use, heat is key, never light a small fire! A small fire in a large, chambered firebox will not produce any heat in the components of the fireplace or in your room. Choose the fire that best suits your living and heating requirements.

Reloading your Kemlan fire –

When it is time to add timber to your fireplace firstly make sure the underside of your white baffles is actually white, if they are still black this will mean the Hardwood has not fully caught alight. If this is the case wait, you will notice as the fire heats up and your seasoned Hardwood is fully lit the baffle plates will return to the original white condition, this means the fire drawing correctly through the flue system and burning cleanly with the secondary air in full swing.

You can now open the air slide fully, crack the door slightly allowing the air pressure to equal then carefully fully open the door.

Have the timber you are going to load in the chamber ready to immediately reload, be prepared, don't open the door and then go looking for the optimal pieces of timber, the longer you wait the colder the chamber will get and the higher the chance of smoke coming back into the room.

Overnight burns –

All medium and large size Kemlan fireplaces have what is called an 'overnight burn' but what does this mean??

Like we have touched on above, the air slide should only be shut down fully when you want an extended length of burn, as soon as you starve the firebox of air the fire will burn dirtier, and heat output will be greatly reduced, in some instances the glass will blacken due to the lack of air movement inside the chamber. The black creosote will burn off the glass when the fire's air control is back up to high with a new load of timber.

If you follow these simple steps, you will find your Kemlan fireplace is one of the best investments you have made to your home.

Generally, a Kemlan medium to large chamber will burn between 8 – 12 hours depending on the quality of fuel/timber and how full you stack the chamber. For maximum burn time you would fill the chamber up to 50mm below the secondary air tubes underneath the white baffle plate. The larger the pieces of timber the better!

After the 8-12 hours you should still have glowing embers in the base of the fire, a small amount of kindling and medium size pieces of hardwood can then be re-loaded making sure the air control has been moved back to 'full left' introducing maximum primary air again.

From everyone in Kemlan we thank you for your business and wish you a lifetime of warmth and enjoyment.

IMPORTANT:

UNDER NO CIRCUMSTANCES SHOULD ANY SOLVENTS SUCH AS METHYLATED SPIRITS, PETROL, MINERAL TURPENTINE ETC OR DETERGENTS, BE ALLOWED TO COME IN CONTACT WITH THE PAINTED SURFACE OF THE HEATER AS DAMAGE TO THE FINISH WILL RESULT. IF AN ACCIDENT DOES OCCUR, SPRAY CAN PAINT IS AVAILABLE FROM YOUR NEAREST KEMLAN DEALER.

WARRANTY

1. Kemlan wood heaters carry a warranty on the 6mm firebox for a period of ten (10) years.
2. This warranty also covers other components of the heater for a period of one (1) year. These components include the baffle plate, handle assembly, secondary air tubes and fan.
3. Kemlan's warranty covers the wood heaters against defects in materials and manufacture.

4. THIS WARRANTY DOES NOT COVER –

- 4.1 Failure to comply with manufacturer's operation instructions.
- 4.2 Normal wear and tear or damage caused by incorrect installation.
- 4.3 Any form of rust and/or corrosion to the painted finish of the heater.
- 4.4 Damage to the glass in the door, if the damage is caused by impact or misuse.
- 4.5 The cost of collection and delivery of the wood heater and/or parts.
- 4.6 Damage caused by water ingress.
- 4.7 Cost of removal of defective heater or re-installation of replacement heater.
- 4.8 Failure to use fireplace components supplied by Kemlan Industries Pty Ltd.
- 4.9 Cost of inspection for damaged heater.

5. CLAIMS –

- 5.1 (I) Kemlan will provide a full replacement of the heater in the first five years after installation.
 - (ii) Replacement in the subsequent five years (i.e. sixth to tenth year after installation will be on the following basis.
Owner will pay fifty percent of the current retail price, if the claim is made in the sixth year – tenth year after purchase.
- 5.2 Replacement of heater subject to all conditions in section four of warranty.
- 5.3 Should any defects occur, contact the Kemlan distributor from whom you purchased the heater.
- 5.4 Under this warranty the defective parts will be repaired or replaced, free of charge.
6. The fireplace installation must comply with the relevant local statutes, ordinances, regulations and by-laws.

7. THIS WARRANTY IS VOID IF:

- 7.1 The appliance has been over-fired or operated in atmospheres contaminated by chlorine, fluorine or other damaging chemicals. Over-firing can be identified by, but not limited to, warped plates or tubes, rust coloured cast iron, bubbling, cracking and discolouration of steel or enamel finishes.

PLEASE COMPLETE AND RETAIN THIS SECTION FOR YOUR RECORDS

Purchased from:
Address:
Date of Purchase:

