

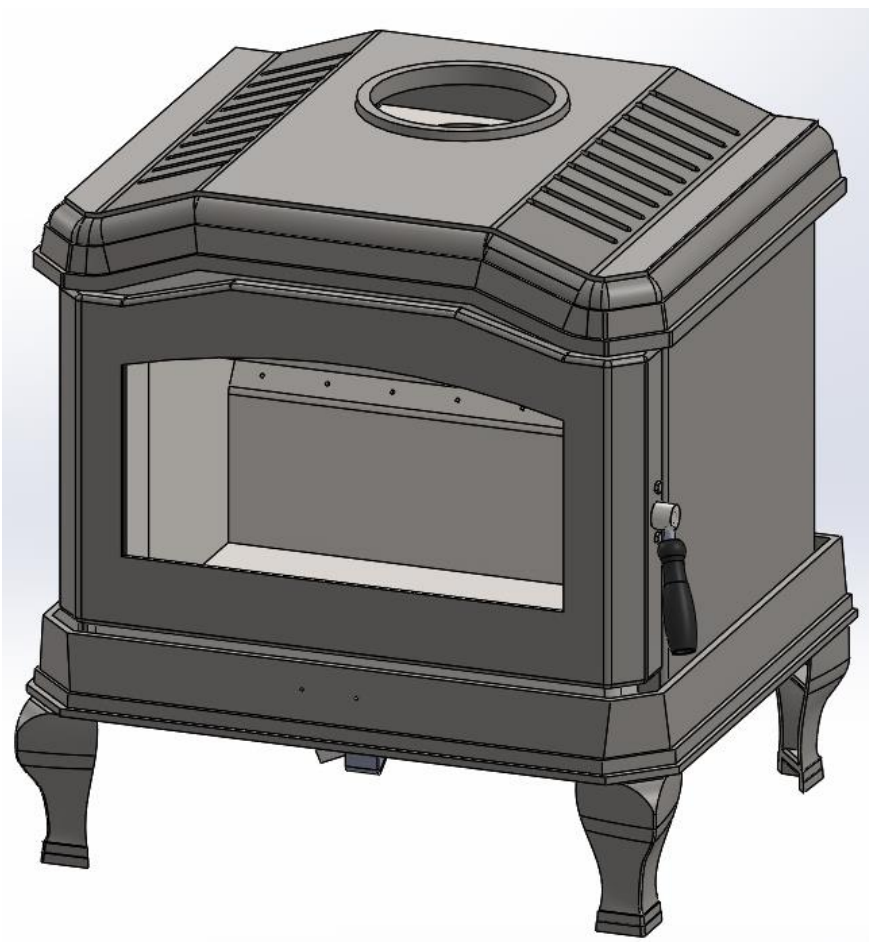

Specialists in fireplace design and manufacture

KEMLAN C24 Mk II
INSTALLATION & OPERATING INSTRUCTIONS



IMPORTANT:

INSTALLER, PLEASE LEAVE THESE INSTRUCTIONS WITH THE UNIT ON COMPLETION.

10 YEAR FIREBOX WARRANTY

**The firebox is covered by a 10 year warranty.
Other parts are covered by a one year limited warranty.**

Head Office - 13 French Avenue, Brendale, Queensland 4500

Telephone - PH: (07) 3490 5500

Facsimile - FAX: (07) 3490 5520

Website - www.jetmaster.com.au

Business hours: - Monday to Thursday 7:30am-4:00pm. Friday 7:30am-2:00pm

Email: - sales@jetmaster.com.au

**PARTICULATE EMISSIONS POWER OUTPUT AND EFFICIENCY TESTING OF
THE KEMLAN C24
FREE STANDING SOLID FUEL APPLIANCE**

Report

The Kemlan C24 solid fuel appliance was tested for particulate emissions power output and efficiency according to the requirements of the joint Australian/New Zealand Standard AS/NZS 4012/4013 (1999).

The appliance particulate emissions factor was 1.4g/kg of hardwood, and the combined efficiency of the appliance for all burn rates was 68%.

The Kemlan C24 solid fuel appliance complies with the requirements of AS/NZS 4012/4013 (1999).

Investigation: S. Marland

Report: S. Marland

Checked by: J. Kaiser

Signed: 
S. Marland
Technical Officer

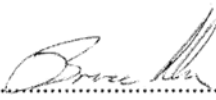
Approved: 
B Ham
Manager Gippsland

**THERMAL CLEARANCE TESTING OF THE
KEMLAN C24 SOLID FUEL
APPLIANCE TESTED WITH A KEMLAN DOUBLE FLUE KIT**

Report

The appliance and flue system were installed into a standard Clearance Test enclosure and tested in two positions in a manner conforming to joint Australian/New Zealand Standard 2918:2001, Appendix B. A minimum 810mm deep x 850mm wide x 6.0mm thick floor protector (cement fibre sheet) should be used under and in front of the appliance base when installing the appliance (see joint AS/NZS 2918:2001 3.3.2). The floor protector should extend 350mm in front of the appliance base. The Thermal conductivity of the floor protector is 0.8 m².K/W for 4mm sheets.

A 900mm x 130 degree stainless rear flue shield must also be installed directly behind the active flue.

The Kemlan C24 solid fuel appliance, when installed with a Kemlan Double flue system, conforms to the requirements of joint AS/NZS 2918:2001, Appendix B, with respect to rear wall, side wall, floor and ceiling surface temperatures, when tested in the positions described in this report and using *Pinus radiata* firewood as the fuel type.

TEST POSITIONS

The appliance and flue combinations were tested at the following clearances:

Position A (Parallel)

150mm from rear wall to the edge of the appliance rear panel.
450mm from side wall to the edge of the appliance side panel.

Position B (Corner)

225mm from walls when measured from the rear corners of the appliance (45° to both walls).

Refer to Appendix 1 of this report for clearance diagrams.

Investigation: J. Kaiser & S. Marland

Report: S. Marland

Checked by: J. Kaiser

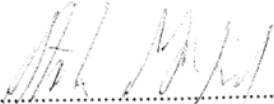
Signed: 

S. Marland
Technical Officer

Approved: 

B. Ham
Manager, Gippsland

DIMENSIONS

C24 Mk II

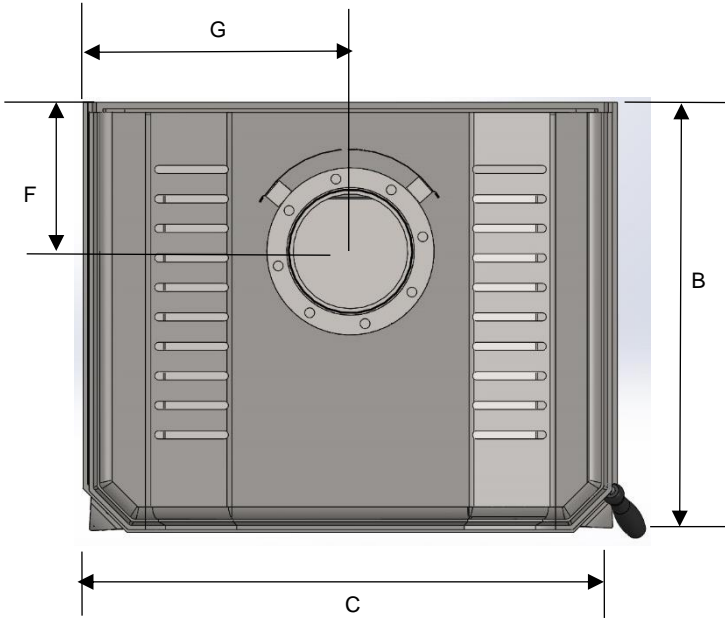

8" DECRO

HEAT SHIELD

THE FIRST LENGTH OF 8" DECRO FROM THE UNIT MUST HAVE DOUBLE HEAT SHIELD

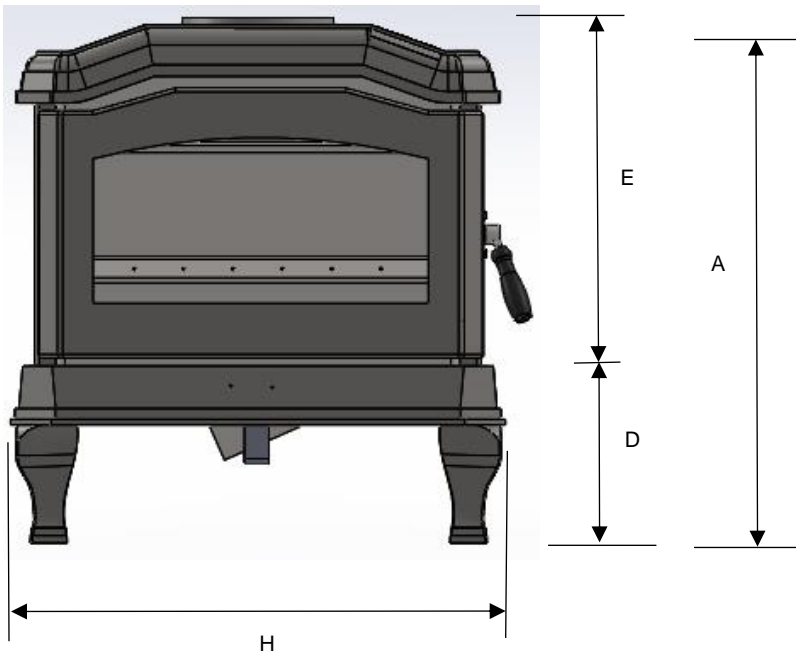
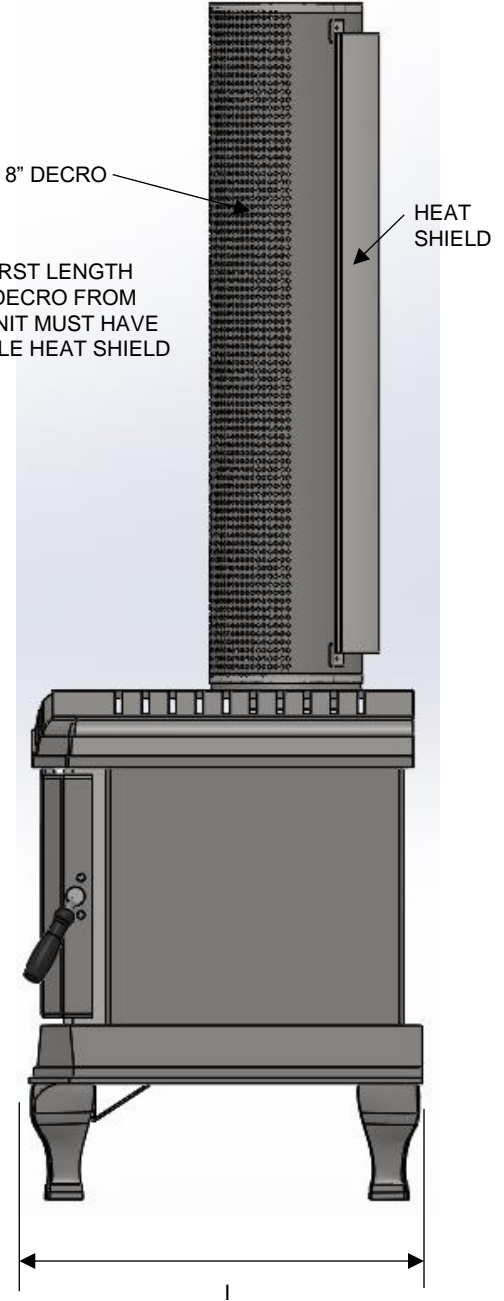

	A	B	C	D	E	F	G	H	I
MEASUREMENT	682	510	638	233	563	170	319	652	525

MINIMUM CLEARANCES FOR THE C24 MkII INSTALLED WITH DEFAULT FLUE KIT

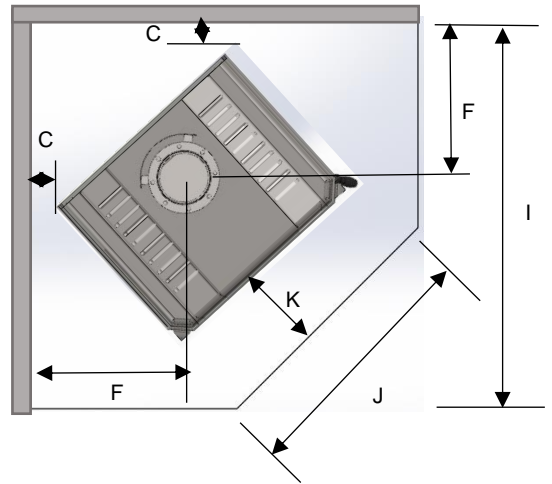
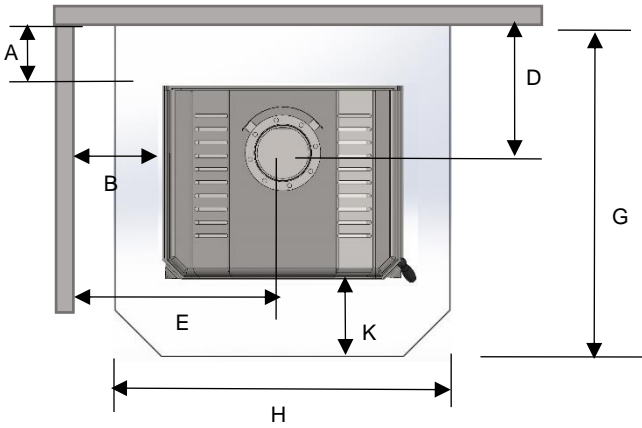

MINIMUM CLEARANCES:

	A	B	C	D	E	F	G	H	I	J	K
MEASUREMENT	150	450	225	320	770	599	1025	850	-	-	350

FAN INSTALLATION INSTRUCTION

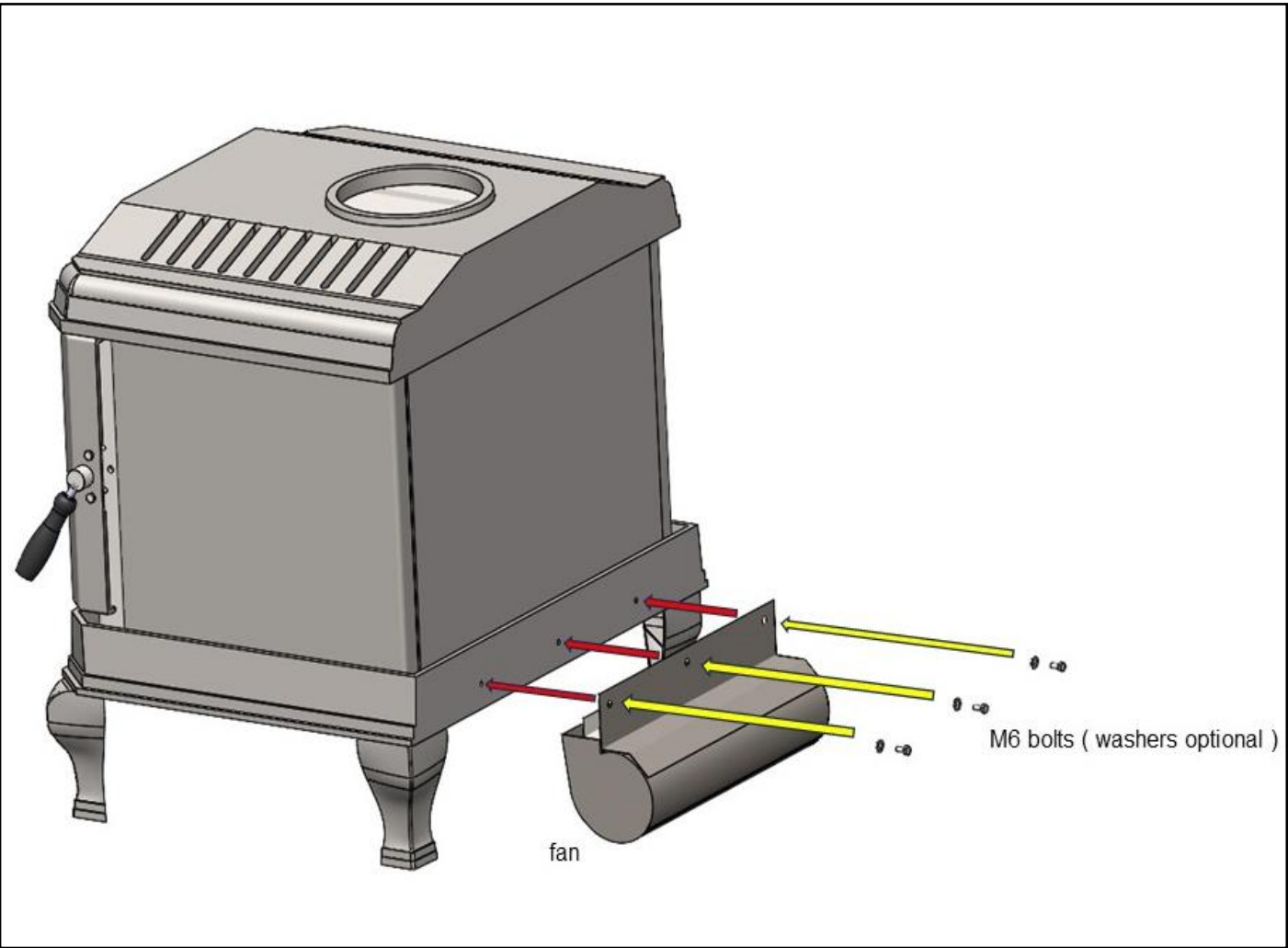

FREESTANDING UNIT WITH HEAT SHIELD

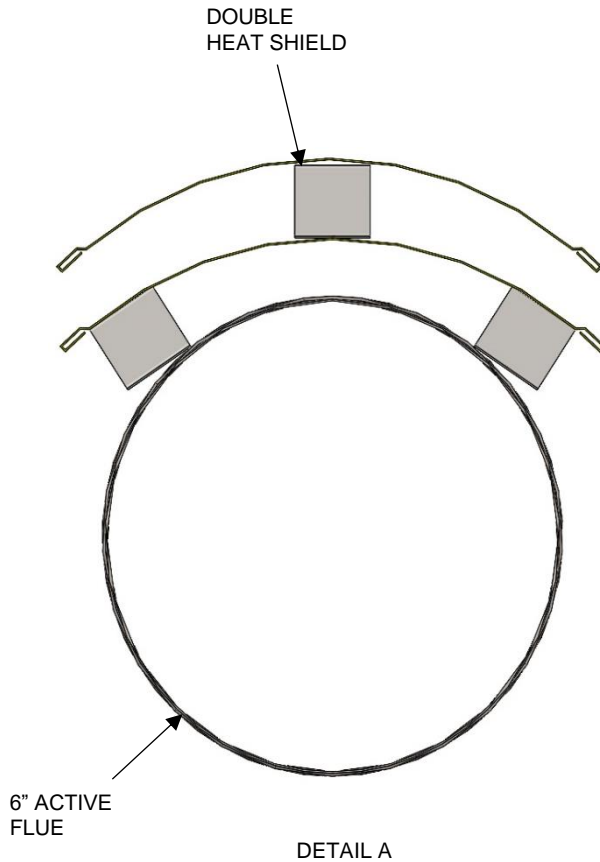

THE HEAT SHIELD WILL COVER 33% OF THE TOTAL CIRCUMFERENCE OF THE ACTIVE FLUE.

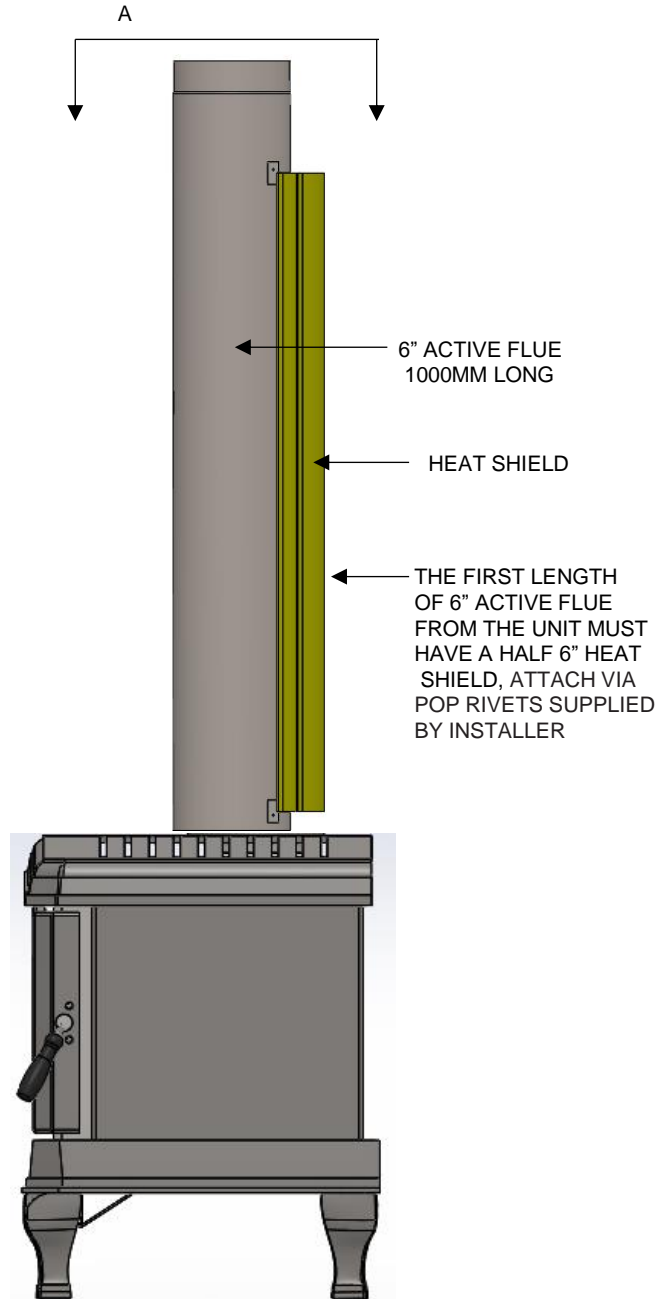

IMPORTANT:

NEW FLUE KIT ACTIVE + HALF HEATSHIELD – “ANY SINGLE HEATSHIELD CAN BE USED FROM 900MM UP TO 1200MM HEIGHT”

“THIS HEATER HAS BEEN TESTED WITH THE FAN CONNECTED TO A STANDARD 3 PIN GPO SOCKET OUTLET. THE FAN DOES NOT NEED TO BE HARD WIRED”.

IMPORTANT: ANY APPENDIX F APPROVED FLUE KITS CAN BE USED ON THESE KEMLAN FREESTANDING FIREPLACES AS LONG AS IT COMPLIES WITH THE LABORATORY TESTED HEAT SHIELDING”

FREESTANDING FLUE KIT (APPENDIX F)

- 2 – 6” STAINLESS STEEL FLUE 1000mm CRIMPED**
- 2 - 6” STAINLESS STEEL FLUE 1000mm CRIMPED, BLACK**
- 1 – 8” GALVANISED FLUE 1000mm PLAIN**
- 1 – 8” GALVANISED FLUE 1000mm CRIMPED**
- 1 – 10” GALVANISED FLUE 1000mm PLAIN**
- 1 - 10” DROP BOX, 6”-10” VENTED CAP,
CRIMPED, BLACK**
- 1 - 6” HEATSHIELD BLACK**
- 2 – ANGLE BRACKETS GALVANISED
1200x50x50mm**
- 1 – 10” ROUND CEILING TRIM, BLACK**
- 1 – 10” RAKED CEILING TRIM**
- 1 – 6” – 10” DOUBLE CONE COWL**
- 1 – SPACING KIT**
- 1 – INSTALLATION INSTRUCTION**

FREESTANDING UNIT WITH HEAT SHIELD (DECRO 8")

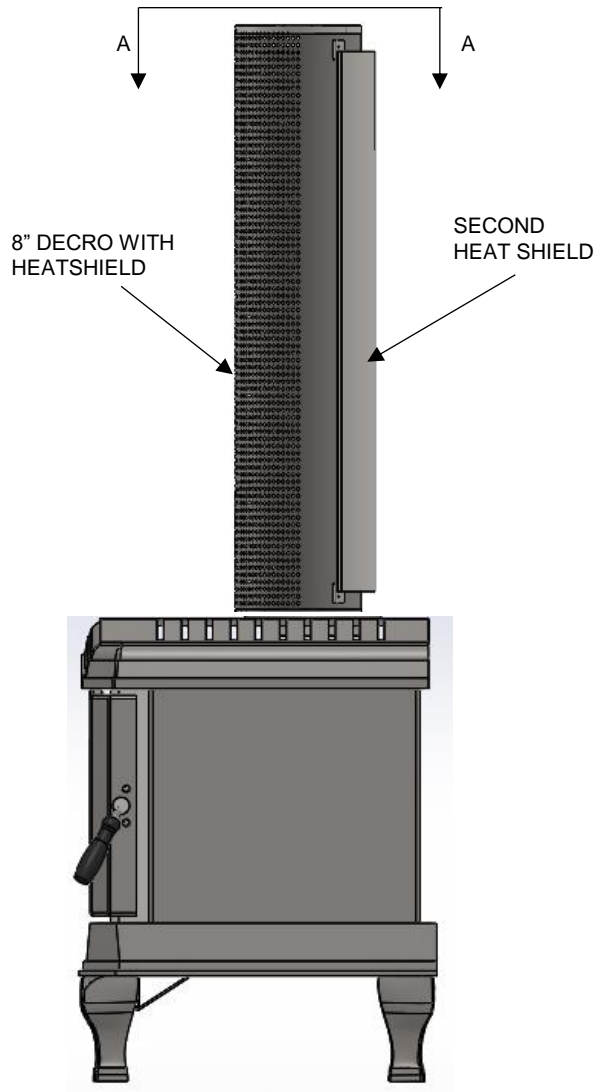
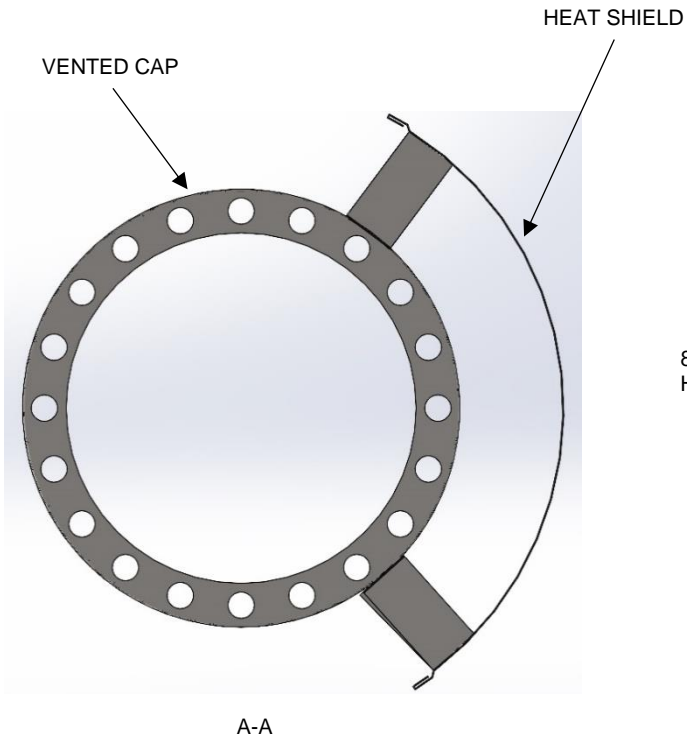

FREESTANDING DECRO FLUE KIT

- 3 – 6” STAINLESS STEEL FLUE 1000mm CRIMPED**
- 1 – 6” STAINLESS STEEL FLUE 1000mm CRIMPED/SWAGED**
- 2 – 8” GALVANISED FLUE 1000mm PLAIN/CRIMPED**
- 1 – 10” GALVANISED FLUE 1000mm PLAIN**
- 1 - 10” DROP BOX, 8”-10” VENTED CAP,
CRIMPED, BLACK**
- 1 – DECROSHIELD (A) 8” -900mm (WITH HEATSHIELD)
BLACK**
- 1 - DECROSHIELD (E) 8” -900mm (WITH HEATSHIELD)
BLACK**
- 2 – ANGLE BRACKETS GALVANISED
1200x50x50mm**
- 1 – ADDITIONAL HEATSHIELD**
- 1 – 10” ROUND CEILING TRIM, BLACK**
- 1 – 10” RAKED CEILING TRIM BLACK**
- 1 – 6” – 10” DOUBLE CONE COWL**
- 1 – SPACING KIT**
- 1 – INSTALLATION INSTRUCTION**

INSTALLATION INSTRUCTION

C24 Mk II FLAT CEILING INSTALLATION

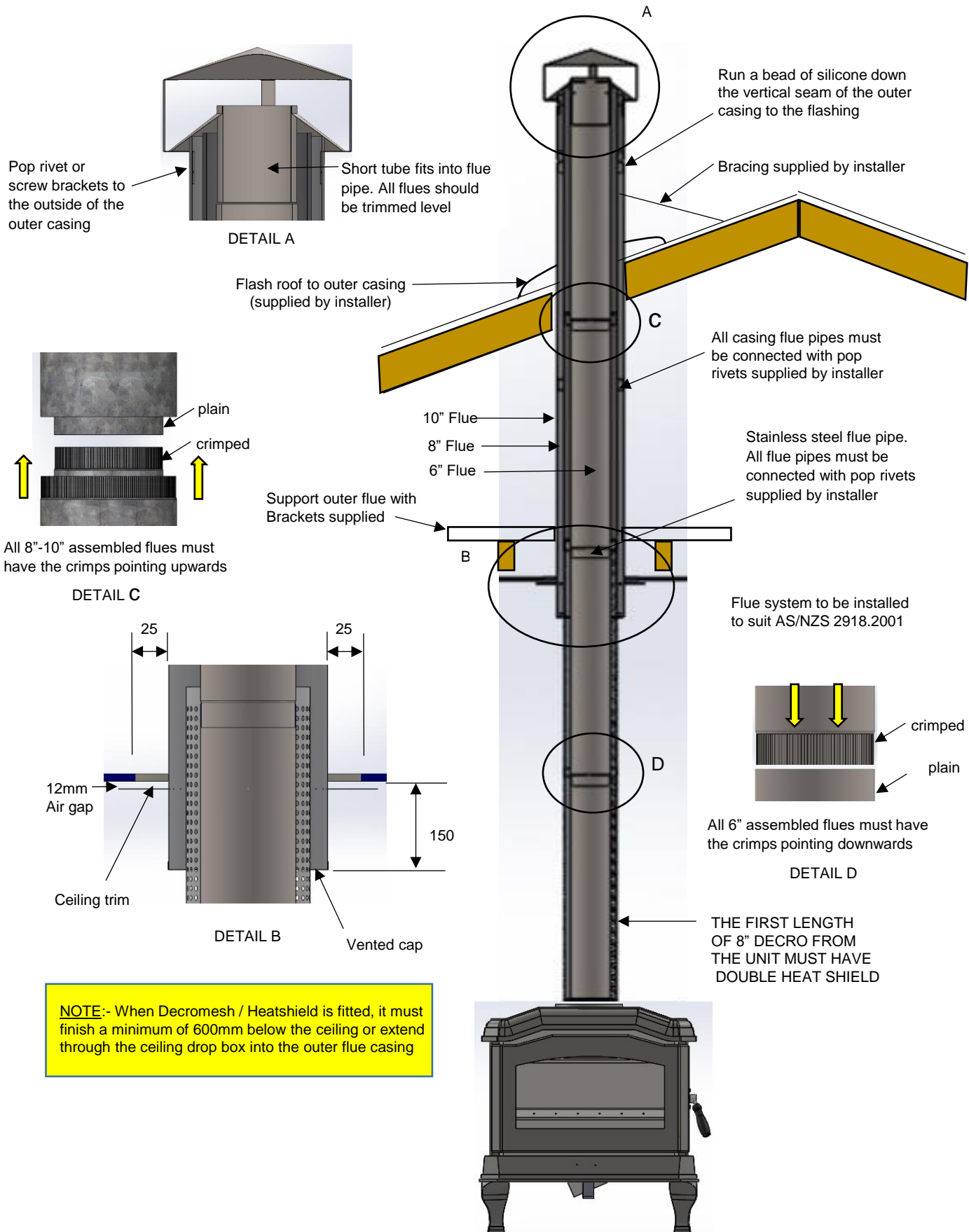

NOTE:- When Decromesh / Heatshield is fitted, it must finish a minimum of 600mm below the ceiling or extend through the ceiling drop box into the outer flue casing

INSTALLATION INSTRUCTION

C24 Mk II RAKED CEILING INSTALLATION

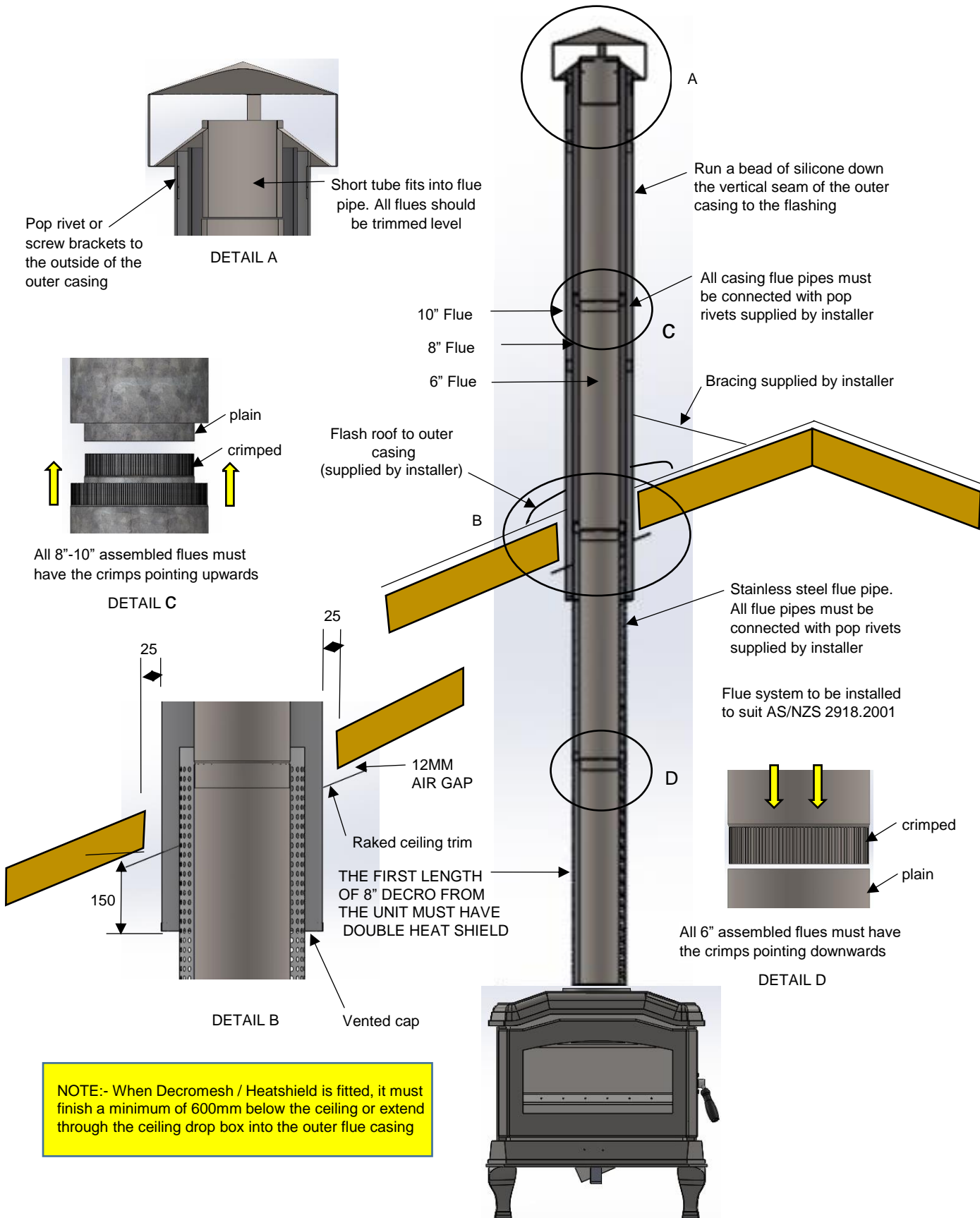

INSTALLATION INSTRUCTIONS

MINIMUM HEIGHT OF FLUE SYSTEM EXIT INSTALLATION TO COMPLY WITH AS/NZS 2918

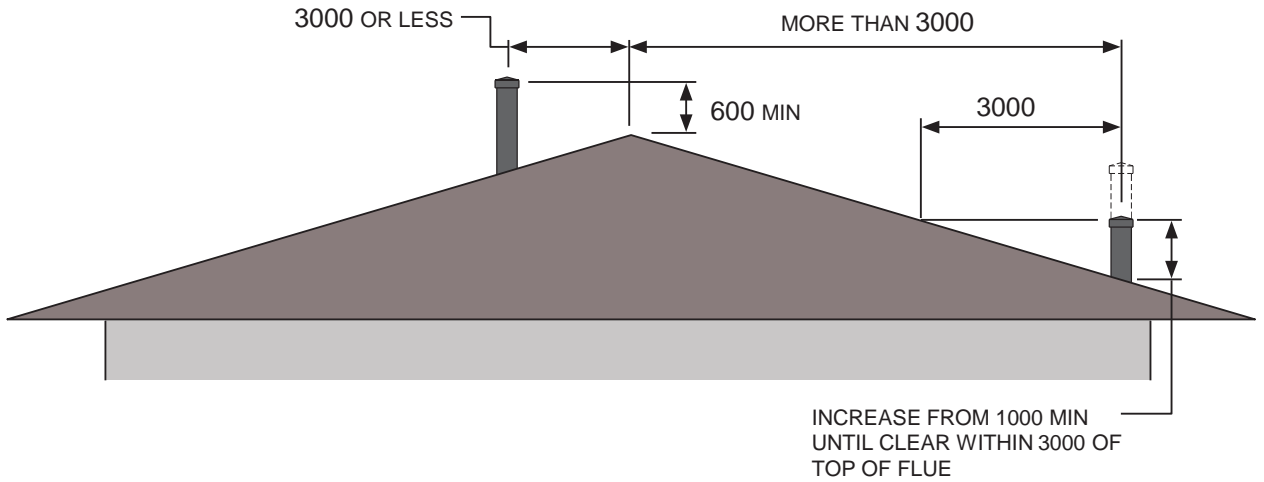
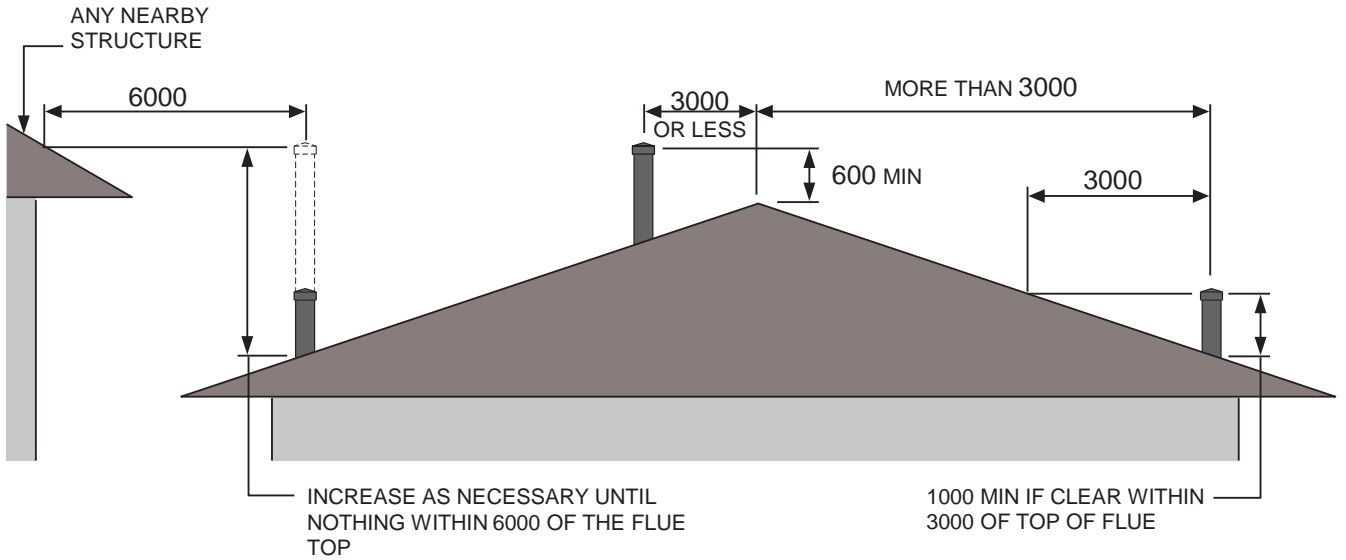

DIMENSIONS IN MILLIMETRES



Certificate of Compliance for **SOLID FUEL HEATERS**

This is to certify that the appliance stated on this certificate has been tested for Heat Output, Thermal Efficiency and Particulate Emissions in accordance with the Australian / New Zealand Standard(s) detailed below

Manufacturer	Kemlan Industries Pty Ltd
Make	Kemlan
Model	C24 MkII
Type	Free-Standing Appliance
Category	Slow Combustion Wood Heater
Fuel Type	Hardwood
Test Report No's:	HCMG/06/009
Maximum Avg Heat Output	11.6kW
Overall Avg Efficiency	68%
Particulate Emissions Factor	1.4g/kg
National Standards	AS/NZS 4012 (2014) AS/NZS 4013 (2014)

ASFT hereby grants to:

Kemlan Industries Pty Ltd

of

59 Pineapple Street, Zillmere Queensland, Australia 4034

Certificate No.: **ASFT21C098e**

Certified Date: **31 July 2006**

Issue Date: **4 February 2025**

Expiry Date: **4 July 2025**

Steve Marland

Managing Director of ASFT

ASFT performs compliance testing of Solid Fuel Appliances to the relevant Australian/New Zealand standards. This certification is subject to the conditions set forth in the characteristics above and is not to be construed as any recommendation, assurance or guarantee by ASFT of the product acceptance by Authorities having jurisdiction.

Australian Solid Fuel Testing, 3 Gardan Street, Morwell, Victoria, Australia 3840
ABN 46 610 154 768

KEMLAN INDUSTRIES

Operating Instructions

Congratulations on the purchase of your Australian made Kemlan slow combustion wood fireplace.

We hope this serves you well, not just as a stunning feature; but as a functional tool for heating your home and keeping you and your family warm however cold the winters may get, because this is what Kemlan specialises in and has perfected, making fires in Brisbane QLD since 1969, 'Australian made for Australian conditions'.

Welcome to the Kemlan family.

I would like to share with you the correct way to operate your Kemlan wood fire giving best results for both heating and useability.

Let's get started:

The First Burns -

Unfortunately, we have no control over how the fire is loaded nor do we have any control over what quality of fuel / timber is used, therefore we can only give recommendations, and this will be the difference in heat output and length of burn.

Hard wood should always be used as the main fuel source in all Kemlan wood heaters at a moisture level of between 12% - 20% (always have a moisture meter).

If the timber is too dry it will burn faster, if the timber is too wet it will struggle to burn at all and give very little heat.

The first few burns in a wood fire are commonly referred to as 'curing burns', this is when you are getting heat into the appliances steel and paint for the first time.

What we are trying to achieve here is 3-fold:

The **first** goal is to get heat into the white ceramic baffles and the steel flue system, getting these 2 things hot will create the 'draw' of the fireplace this is the process in which the smoke is drawn out of the fireplace chamber through the flue system.

The **second** goal is to lay a bed of ash in the base of the fire, ash in the bottom of the fire is essential to the performance of the fireplace, the optimal thickness of ash is 2-3 Inches (25mm - 75mm).

Having this bed of ash will assist the fuel to light easier creating an air layer under the timber, it will also assist in a longer hotter burn as the ash holds a large amount of the heat while the timber above is burning. So DO NOT clean your ash out until you have to, you should never see the firebricks in the base of your fire.

The **third** goal of the initial burns is to cure the paint on the fireplace casing, Kemlan fires are painted with a high temperature paint. When first applied at our factory, the paint is very soft, we place all finished fireplaces under heat lamps to start the 'curing' process but because of the time it takes and

the temperature the casing needs to stay at to complete this process we need YOU to finish this cure in your home by lighting your new fire! So, let's do it!.....

Building your fire -

Whether you have purchased a small, medium or large chamber fireplace the set-up is the same.

Kemlan introduce more primary air into the chamber of the fireplace than most other brands on the market, this makes it very easy to light the fire from a cold start, it also makes it easy for you the user of the fireplace to load the paper or firelighters, kindling (small pieces of soft wood) and hard wood into the chamber straight away.

Your goal should be to fill the fireplace chamber front to back, sided to side to make sure heat is evenly distributed throughout the entire firebox.

We don't want to have to keep tending to the fireplace slowly adding pieces of timber and constantly opening the door, one full load of timber is far better.

Scan the QR code below to access the 'How to stack and light your Kemlan wood fire' video.

Please take some time to watch to see if your process is the same.



Now your Kemlan fire is up and running make sure to keep the primary air slide fully open, this will ensure maximum oxygen is getting to the fuel and this will create quicker heat into the fireplace box, baffle, flue and of course your home.

The air slide can move from extreme left (fully open) to extreme right (fully closed).

Think of this slide like an accelerator and brake on a car. Fully open would be putting your foot down on your car's accelerator, fully closed is like putting the breaks on in the car.

When we want energy into the room (KW) we want the slide open, as the room gets to the desired temperature the air slide can be moved towards the right-hand side reducing the air to the chamber slowing the energy output and fuel consumption.

The air slide should only be moved half to $\frac{3}{4}$ of the way across while you can still tend to the fire, closing it completely or starving the fire should only be done when you cannot tend to the fire for long periods of time (e.g. going to bed) when your only goal is for length of burn.

Remember no matter whether it is a curing burn or an everyday use, heat is key, never light a small fire! A small fire in a large, chambered firebox will not produce any heat in the components of the fireplace or in your room. Choose the fire that best suits your living and heating requirements.

Reloading your Kemlan fire -

When it is time to add timber to your fireplace firstly make sure the underside of your white baffles is actually white, if they are still black this will mean the hardwood has not fully caught alight. If this is the case wait, you will notice as the fire heats up and your seasoned hardwood is fully lit the baffle plates will return to their original white condition, this means the fire drawing correctly through the flue system and burning cleanly with the secondary air in full swing.

You can now open the air slide fully, crack the door slightly allowing the air pressure to equal then carefully fully open the door.

Have the timber you are going to load in the chamber ready to immediately reload, be prepared, don't open the door and then go looking for the optimal pieces of timber, the longer you wait the colder the chamber will get and the higher the chance of smoke coming back into the room.

Overnight burns -

All medium and large size Kemlan fireplaces have what is called an 'overnight burn' but what does this mean??

Like we have touched on above, the air slide should only be shut down fully when you want extended length of burn, as soon as you starve the firebox of air the fire will burn dirtier and heat output will be greatly reduced, in some instances the glass will blacken due to the lack of air movement inside the chamber. The black creosote will burn off the glass when the fire's air control is back up to high with a new load of timber.

Generally, a Kemlan medium to large chamber will burn between 8 - 12 hours depending on the quality of fuel/timber and how full you stack the chamber. For maximum burn time you would fill the chamber up to 50mm below the secondary air tubes underneath the white baffle plate. The larger the pieces of timber the better!

After the 8-12 hours you should still have glowing embers in the base of the fire, a small amount of kindling and medium size pieces of hardwood can then be re-loaded making sure the air control has been moved back to 'full left' introducing maximum primary air again.

If you follow these simple steps, you will find your Kemlan fireplace is one of the best investments you have made to your home.

From everyone in Kemlan we thank you for your business and wish you a lifetime of warmth and enjoyment.

IMPORTANT:

UNDER NO CIRCUMSTANCES SHOULD ANY SOLVENTS SUCH AS METHYLATED SPIRITS, PETROL, MINERAL TURPENTINE ETC OR DETERGENTS, BE ALLOWED TO COME IN CONTACT WITH THE PAINTED SURFACE OF THE HEATER AS DAMAGE TO THE FINISH WILL RESULT. IF AN ACCIDENT DOES OCCUR, SPRAY CAN PAINT IS AVAILABLE FROM YOUR NEAREST KEMLAN DEALER.

WARRANTY

1. Kemlan wood heaters carry a warranty on the 6mm firebox for a period of ten (10) years.
2. This warranty also covers other components of the heater for a period of one (1) year. These components include the baffle plate, handle assembly, secondary air tubes and fan.
3. Kemlan's warranty covers the wood heaters against defects in materials and manufacture.

4. THIS WARRANTY DOES NOT COVER –

- 4.1 Failure to comply with manufacturer's operation instructions.
- 4.2 Normal wear and tear or damage caused by incorrect installation.
- 4.3 Any form of rust and/or corrosion to the painted finish of the heater.
- 4.4 Damage to the glass in the door, if the damage is caused by impact or misuse.
- 4.5 The cost of collection and delivery of the wood heater and/or parts.
- 4.6 Damage caused by water ingress.
- 4.7 Cost of removal of defective heater or re-installation of replacement heater.
- 4.8 Failure to use fireplace components supplied by Kemlan Industries Pty Ltd.
- 4.9 Cost of inspection for damaged heater.

5. CLAIMS –

- 5.1 (i) Kemlan will provide a full replacement of the heater in the first five years after installation.

(ii) Replacement in the subsequent five years (i.e. sixth to tenth year after installation will be on the following basis.
Owner will pay fifty percent of the current retail price, if the claim is made in the sixth year – tenth year after purchase.
- 5.2 Replacement of heater subject to all conditions in section four of warranty.
- 5.3 Should any defects occur, contact the Kemlan distributor from whom you purchased the heater.
- 5.4 Under this warranty the defective parts will be repaired or replaced, free of charge.
6. The fireplace installation must comply with the relevant local statutes, ordinances, regulations and by-laws.

7. THIS WARRANTY IS VOID IF:

- 7.1 The appliance has been over-fired or operated in atmospheres contaminated by chlorine, fluorine or other damaging chemicals. Over-firing can be identified by, but not limited to, warped plated or tubes, rust coloured cast iron, bubbling, cracking and discolouration of steel or enamel finishes.

PLEASE COMPLETE AND RETAIN THIS SECTION FOR YOUR RECORDS

Purchased from:
Address:
Date of Purchase: